

Boston Gear[®]

Worm Gear Speed Reducers

P-3009-BG

Installation and Operation

Doc. No. 57746

700 Series
Single and Double
Reductions



a division of **Altra Industrial Motion**



Inadequate lubrication is by far the largest contributor to premature failures of worm gear drives, applied within proper selection practice.

While lubricant selection is important to all gear reducers, it is critical for the worm gear type. Sliding action at the tooth mesh dictates use of a relatively high viscosity oil with special characteristics. A recent survey indicated improper lubricants were used in two-thirds of the applications. Although lightly loaded drives may survive, optimum performance is not obtained.

Boston Gear now offers Klübersynth UH1-6-460 Synthetic Lubricating Oil as a premium lubricant with many outstanding benefits for worm gear applications.

- Reduction in maintenance costs due to extended time between oil changes.
- Increased ratings providing for smaller drive selection or longer gear life.
- Lower energy consumption from improved efficiency.
- Broad ambient temperature range due to high viscosity temperature.
- Longer seal life, based on lower operating temperature.
- Multi-purpose application, including most other types of gear drives.

Lubrication Instructions

WARNING - Boston Gear speed reducers are normally shipped without lubricant. They must be filled to the proper level with the recommended lubricant for your application before operation.

The recommended lubricant table indicates the type and viscosity of lubricant suitable for reducers operating at various temperatures.

Lubrication and maintenance instructions are provided with each speed reducer. These instructions should be followed for best results. It is important that the proper type of oil be used since many oils are not suitable for the lubrication of gears. Various types of gearing require different types of lubricants.

The lubricant must remain free from oxidation and contamination by water or debris, since only a very thin film of oil stands between efficient operation and failure. To assure long service life, the reducer should be periodically drained (preferably while warm) and refilled to the proper level with a recommended gear oil. Under normal environmental conditions oil changes are suggested after the initial 250 hours or every 6 months.

Synthetic lubricants will allow extended lubrication intervals due to its increased resistance to thermal and oxidation degradation. It is suggested that the initial oil change be made at 1500 hours and, thereafter, at 5000 hour intervals.

During the initial period of operation, higher than normal operating temperatures may be seen. This is due to the initial break-in of the worm gear set. The temperature of Double Reduction Worm Gear Reducers may reach 160°F and Single Reduction Worm Gear Reducers approximately 225°F.

These instructions must be read thoroughly before installing or operating speed reducers. File instructions for future reference and for ordering of replacement parts.

General Instructions

1. Align all shafts accurately. Improper alignment can result in failure. Use of flexible couplings is recommended to compensate for slight misalignment.
2. When mounting, use maximum possible bolt size and secure reducer to a rigid foundation. Periodic inspection of all bolts is recommended.
3. Auxiliary drive components (such as sprockets, gears and pulleys) should be mounted on the shafts as close as possible to the housing to minimize effects of overhung loads. Avoid force fits that might damage bearings or gears.
4. For hollow-shaft speed reducers, place speed reducer as close as possible to supporting bearing on drive shaft. Spot-drill driven shaft for setscrews in severe applications. See kit instructions for reaction rod assembly.
5. Check and record gear backlash at installation and again at regular intervals. This should be done by measuring the rotary movement of the output shaft (rotating alternately clockwise and counterclockwise) at a suitable radius while holding the input shaft stationary. Gears should be replaced when the backlash exceeds four times the measurement taken at installation.
6. Gear drives are rated for 1750 input RPM and Class I Service (Service Factor 1.0), using Klubersynth UH1-6-460 synthetic lubricant. For lower input speeds or for different service classes or lubricants, see catalog selection pages for rating information.
7. Initial operating temperatures may be higher than normal during the break-in period of the gear set. **FOR MAXIMUM LIFE, DO NOT ALLOW THE SPEED REDUCER TO OPERATE CONTINUOUSLY ABOVE 225°F AT THE GEAR CASE.** In the event of overheating, check for overloads or high ambient temperatures. Keep shafts and vent plugs clean to prevent foreign particles from entering seals or gear housing.
8. All reducers should be checked to see if they have been lubricated. Prelubed 700 Series reducers will have a solid plug in the vent hole which must be replaced by the vent plug at time of installation.

CAUTION – If the motor does not readily seat itself, check to determine if key has moved axially along motor shaft, causing interference. Staking of the keyway adjacent to the motor key will facilitate this procedure.

Key Staking Instructions

Lightly tap area of keyway adjacent to key. This will upset material and not allow key to move axially when assembling to speed reducer.

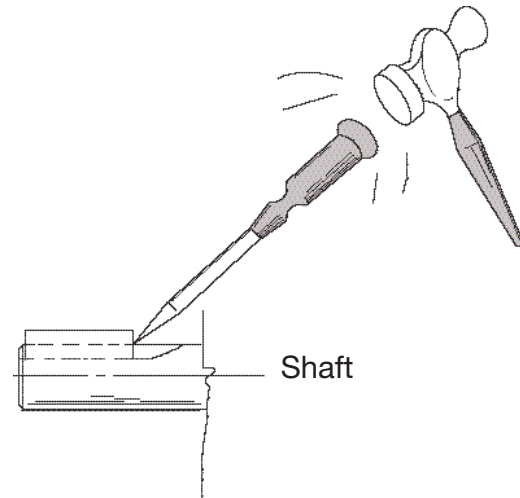

CAUTION

- For safe operation of any gear drive, all rotating shafts and auxiliary components must be shielded to conform with applicable safety standards. You must consider overall operational system safety at all times.
- When using a speed reducer to raise or lower a load, such as in hoisting applications, provision must be made for external braking. Under no conditions should a speed reducer be considered self-locking.
- Mounting of speed reducers in overhead positions may be hazardous. Use of external guides or supports is strongly recommended for overhead mounting.

Instructions for Flanged Models

F700 (Quill Type Input)

1. Assemble the key to the motor shaft and coat the shaft with anti-seize compound. Insert the motor shaft into the reducer input shaft.

2. Rotate the motor to proper position and firmly secure to flange with four hex-head cap screws.

RF700 (Coupling Input – 3-Jaw Type)

1. Coat reducer input and motor shaft with anti-seize compound.
2. Position coupling half on input shaft with shaft flush to end of coupling bore.
3. Locate remaining half on motor shaft, with 1/32" clearance between jaw surfaces.
4. Tighten setscrews securely. For reversing applications, a thread-locking compound is recommended.
5. Install coupling insert and position motor. Rotate motor to proper position and firmly secure to flange.

QC700 (Coupling Input-3-Jaw Quick Connect Type)

1. Coat motor shaft with anti-seize compound.
2. Install motor coupling half onto motor shaft. Use a straight edge to align coupling jaw top end flush with motor shaft except 738-B9 which will be flush with bottom of jaw. Secure with set screw.
3. Install urethane spider insert on motor coupling half.
4. Insert D-Bore coupling half into urethane spider element.
5. Rotate reducer input shaft so “milled flats” are either vertical or parallel. Rotate motor coupling D-Bore to match the reducer milled flats. Coat “D” flats with anti-seize compound furnished with speed reducer.
6. Insert motor assembly into reducer flange assembly. Minor rotating of the motor may be necessary to facilitate D-Bore alignment.
7. Once aligned, push motor towards reducer until properly seated against the face of the reducer flange.
8. Insert (4) hex head cap screws into the designated locations and securely tightened.

Oil Capacities

Single Reduction Models Only

Oil Levels for typical mounting positions

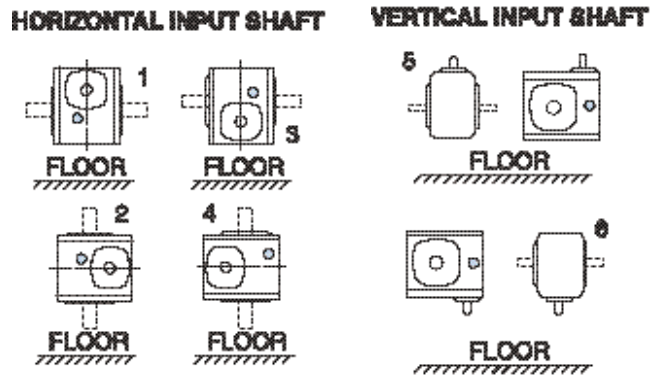

CAUTION - Avoiding those positions where the high speed oil seal is immersed in oil will provide greater security against high speed input seal wear.

Oil Capacity in Fluid Ounces

Unit Size	Positions				
	1	2	3	4	5 & 6
710	2.2	3.3	3.3	3.3	3.3
713	5.5	7.0	7.0	7.0	5.5
715	10.0	15.0	15.0	13.5	13.5
718	12.0	16.0	18.5	16.0	16.0
721	15.0	20.5	20.5	19.0	19.0
724	18.0	24.5	28.5	24.5	24.5
726	28.0	36.0	43.0	36.0	36.0
730	44.0	60.0	67.0	60.0	60.0
732	58.0	84.0	90.0	80.0	80.0
738	85.0	120.0	130.0	120.0	107.0
752	204.0	240.0	245.0	240.0	215.0
760	330.0	400.0	415.0	400.0	370.0

Double Reduction Models

The variety of mounting possibilities for double reduction drives makes it impractical to illustrate positions for these models. In general, the vent filler is at the uppermost plug position, and the drain plug at the lowest possible position. The oil level must be at the approximate centerline of the uppermost gear.

Recommended Lubricants

Enclosed Worm Gear Reducers

Ambient (Room) Temperature	Recommended Oil (or equivalent)	Viscosity Range SUS @ 100°F	Lubricant AGMA No.	ISO Viscosity Grade No. +
-30° to 225°F** (-34° to 107°C)	Klubersynth* UH1-460 Synthetic	1950/2500	-----	460
30° to 225°F (-34° to 107°C)	Mobil SHC634 Synthetic	1950/2500	-----	320/460

Worm Gear Lubricants Available from Boston Gear

Order By Item Code

Type	Klubersynth	Mobil SHC634
Size	QT.	QT.
Item Code	65159	51493

CAUTION: Relubricate more frequently if drive operated in high ambient temperatures or unusually contaminated atmosphere. High loads and operating temperatures will also require more frequent lubrication.

*Synthetic recommendation is exclusively for Klubersynth UH1-6-460.

+Other lubricants corresponding to AGMA/ISO numbers are available from all major oil companies.

**The synthetic lubricant will perform at temperatures considerably higher than 225°F. However, the factory should always be consulted prior to operating at higher temperatures as damage may occur to oil seals and other components.

Lubricant Interchange

1. Ambient temperature is based upon 1.0 service factor.
2. Lubricants are compounded for use in worm gears. Some contain non-corrosive, extreme pressure additives. DO NOT USE lubes that contain sulphur and/or chlorine which are corrosive to bronze gears. Extreme pressure lubes, in some cases contain materials that are toxic. Avoid use of these lubes where they can result in harmful effects. If in doubt, consult your lube supplier.

Manufacturer	Lubricant Name	AGMA Rating
Getty Refining Co.	Veedol Asreslube 98	8 EP
Getty Refining Co.	Veedol Asreslube 95	7 EP
Getty Refining Co.	Veedol Asreslube 90	6 EP
Lubrication Engr. Inc.	Almasol 609	8
Lubrication Engr. Inc.	Almasol 608	7
Mobil Oil Corp.	Mobilgear 634	8 EP
Mobil Oil Corp.	Mobil Extra Hecla Super	8
Mobil Oil Corp.	Mobil Cylinder 600W	7
Shell Oil Co.	Omala 460	7 EP
Shell Oil Co.	Valvala J460	7
Shell Oil Co.	Omala 680	8 EP
Shell Oil Co.	Valvala J680	8
Texaco Inc.	Meropa 680	8 EP
Texaco Inc.	Meropa 460	7 EP

PosiVent® Option

Units supplied with this option are Lubed-for-Life and do not require oil change.

These units are factory filled with Klubersynth UH1-6-460 for universal mounting. To ensure that the system operates properly, DO NOT REMOVE THE VENT PLUG.

Lubrication Instructions

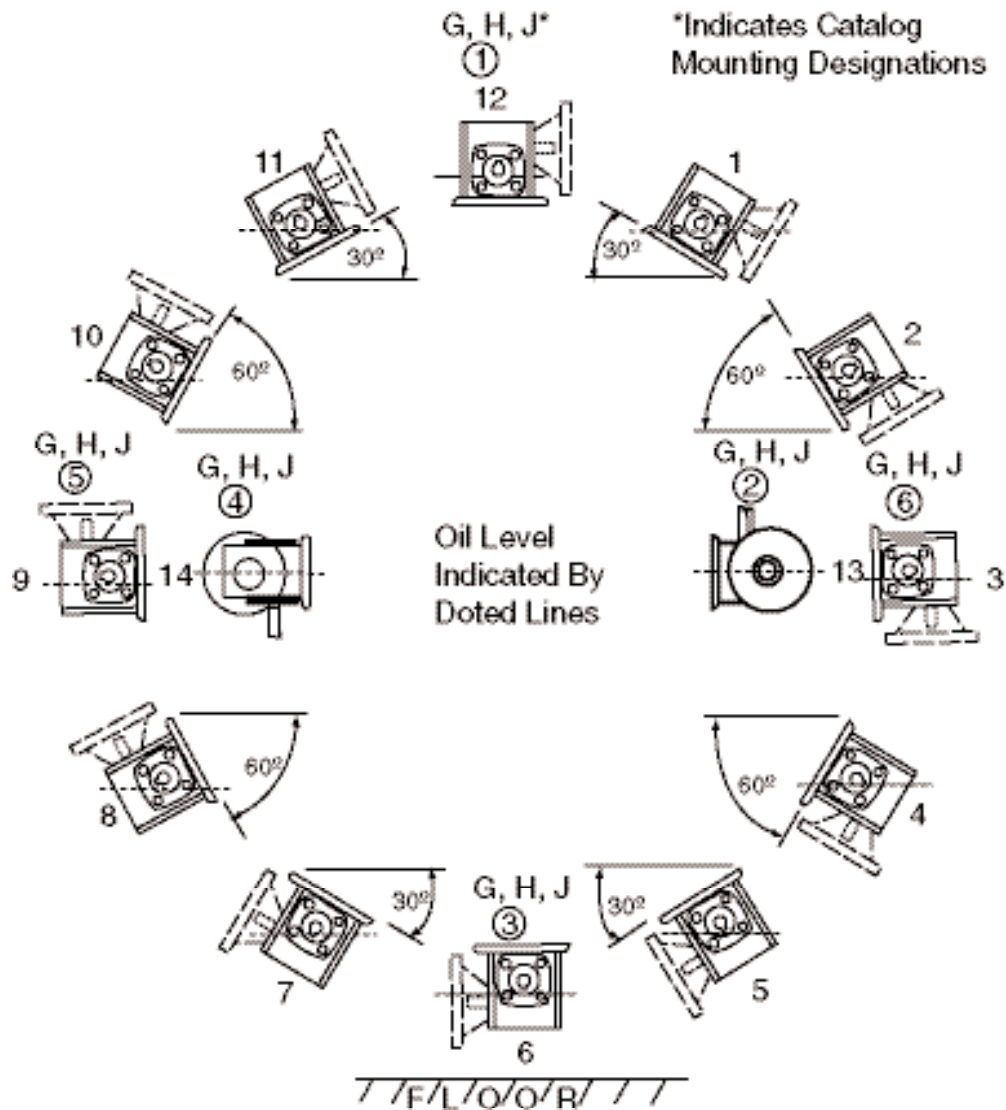

For Single Reduction Only: Refer To Lubrication & Installation Instructions

	Unit Size												
	Position	710	713	715	718	721	724	726	730	732	738	752	760
Oil Capacity In Ounces	1	3.00	6.37	9.30	12.85	14.04	16.97	28.50	42.60	56.80	71.60	162.0	255.7
	2	3.30	7.16	9.25	15.04	16.81	19.93	32.00	50.00	67.30	79.70	195.2	265.9
	3	3.30	5.50	13.50	16.00	19.00	24.50	36.00	60.00	80.00	107.0	215.0	370.0
	4	3.55	7.98	12.06	18.00	20.28	24.95	37.70	57.00	77.10	102.0	209.5	321.7
	5	3.98	8.18	12.30	18.69	21.45	26.95	40.00	60.40	80.90	106.7	192.0	357.0
	6	3.30	7.00	15.00	18.50	20.50	28.50	43.00	67.00	90.00	130.0	245.0	415.0
	7	3.98	8.18	12.30	18.69	21.45	26.95	40.00	60.40	80.90	106.7	192.0	357.0
	8	3.55	7.96	12.06	18.00	20.28	24.95	37.70	57.00	77.10	102.0	209.5	321.7
	9	3.30	5.50	13.50	16.00	19.00	24.50	36.00	60.00	80.00	107.0	215.0	370.0
	10	3.31	7.16	9.25	15.04	16.81	19.93	32.00	50.00	67.30	79.70	195.2	265.9
	11	3.00	6.37	9.30	12.85	14.04	16.97	28.50	42.60	56.80	71.60	162.0	255.7
	12	2.20	5.50	10.00	12.00	15.00	18.00	28.00	44.00	58.00	85.00	204.0	330.0
	13	3.30	7.00	15.00	16.00	20.00	24.50	36.00	60.00	84.00	120.0	240.0	400.0
	14	3.30	7.00	13.50	16.00	19.00	24.50	36.00	60.00	80.00	120.0	240.0	400.0

Parts List – Single Reduction Models

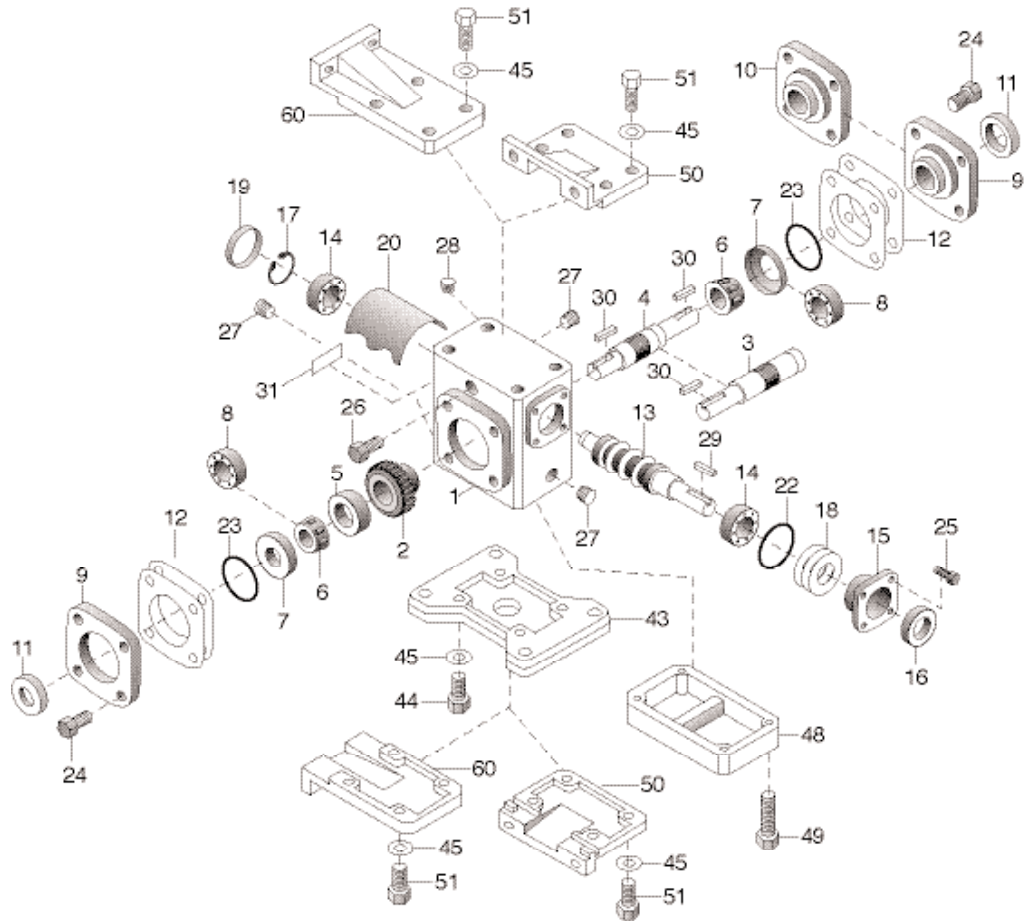

Part No.	Description
1	HOUSING
2*	WORM GEAR
3*	SINGLE PROJECTING OUTPUT SHAFT
4*	DOUBLE PROJECTING OUTPUT SHAFT
5*	GEAR SPACER
6*	OUTPUT BEARING (CONE) – MODELS 713-760
7	OUTPUT BEARING (CUP) – MODELS 713-760
8	OUTPUT BEARING – MODEL 710 ONLY
9	BEARING CARRIER (OPEN)
10	BEARING CARRIER (CLOSED)
11*	OUTPUT OIL SEAL
12*	ADJUSTMENT SHIMS
13	INPUT WORM SHAFT
14	INPUT BEARING – MODELS 710-730
15	INPUT BEARING RETAINER
16	INPUT OIL SEAL – MODELS 710-760
17	RETAINING RING
18	ADJUSTMENT SHIMS
19	BORE PLUG – MODELS 710-730
20	INTERNAL BAFFLE – MODELS 713-732
22	INPUT “O” RING
23*	OUTPUT “O” RING
24	HEX HEAD CAP SCREW
25	HEX HEAD CAP SCREW
26**	VENT PLUB - 2 PIECE

Part No.	Description
27	PIPE PLUG
28	PROTECTIVE CAP PLUG
29	INPUT KEY
30	OUTPUT KEY
31	NAMEPLATE
32	INPUT BEARING (CUP) – MODELS 732-760
33	INPUT BEARING (CONE) – MODELS 732-760
34	GREASE CUPS – MODELS 732-760
35	HEX HEAD CAP SCREW
37	OUTPUT SHAFT KEY – MODELS 730-760
38	RETAINING RING – MODELS 710-738
39	MOTOR SHAFT – MODELS 710-738
40	MOTOR FLANGE – MODELS 710-738
41	OIL SEAL – MODELS 710-738
42	HEX HEAD CAP SCREW
43	HORIZONTAL BASE
44	HEX HEAD CAP SCREW
45	LOCKWASHER
46	2 PIECE FC COUPLING – WITH INSERT
47	RETAINING MOTOR FLANGE
48	RISER BLOCK
49	HEX HEAD CAP SCREW
50	VERTICAL BASE (HIGH OR LOW)
51	HEX HEAD CAP SCREW

Part No.	Description
60	VERTICAL BASE (X & Y ASSEMBLY)
101	FAN
102	SPACER
103	HEX HEAD CAP SCREW
104	FAN GUARD
105	HEX HEAD CAP SCREW
106	WASHER
165	HOLLOW OUTPUT SHAFT (S VERSION ONLY)
166	HOLLOW OUTPUT SHAFT (H VERSION ONLY)
167	WORM GEAR
168	OUTPUT BEARING (CONE)
169	OUTPUT BEARING (CUP)
170	OIL SEAL
171	BEARING CARRIER
172	HOLLOW SHAFT MTG. BRACKET
173	HEX HEAD CAP SCREW
174	LOCKWASHER
175	KEY (INTERNAL)
176	KEY (EXTERNAL)
177	“V” TYPE BASE-MODEL 718, 721, 726, 732)
178	SOCKET SETSCREW

*For Models 710 to 726, these parts are available as complete assemblies. See Part Ordering Information, page 8.

**Extension not required on single reduction Models 713 through 732.

Options & Accessories – Single Reduction Models

<p>Hollow Output Shaft Models S and SF718-732*</p> <p>MODEL 02</p>	<p>Models 732-760</p>
<p>HOLLOW OUTPUT Shaft Models H, HF, and HQC713-738</p>	<p>Models QC710-QC738, RF752-RF760</p>
<p>Models F710-F738</p>	<p>Fan kit for models 732-760</p>

Part ordering information

1. Be sure to provide complete Boston Gear catalog number from speed reducer nameplate, along with part description and number. For example, "One output oil seal, Part No. 11, for RF718-30-B5-G".
2. Output shaft components for Boston Gear models 710 through 726 are available only as complete assemblies that include Parts 2, 3, 5, 6, 11, 12 and 23 for single projecting shafts; and Parts 2, 4, 5, 6, 11, 12 and 23 for double projecting shafts. When ordering, specify "output shaft assembly" and full Boston Gear catalog number from nameplate.

* Not available in the 730 center distance, see H series.

Parts List – Double Reduction Models

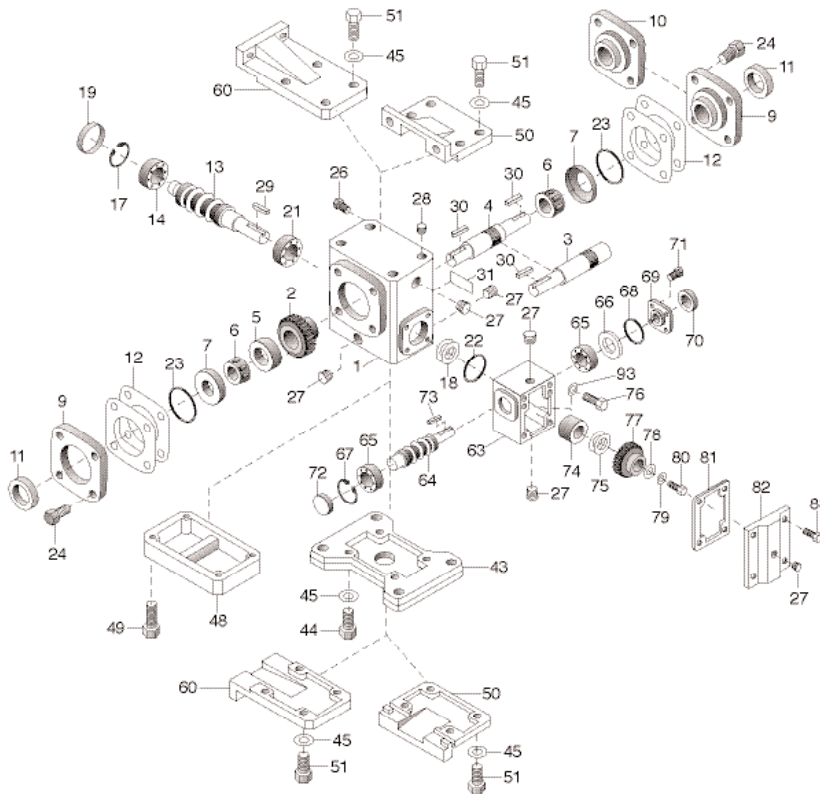

Part No.	Description	Part No.	Description	Part No.	Description
1	HOUSING	31	NAMEPLATE	78	WASHER
2*	WORM GEAR	32	INTER. BEARING (CUP) – MODELS W732-W760	79	LOCKWASHER
3*	SINGLE PROJECTING OUTPUT SHAFT	33	INTER. BEARING (CONE) – MODELS W732-W760	80	HEX HEAD CAP SCREW
4*	DOUBLE PROJECTING OUTPUT SHAFT	34	GREASE CUPS – MODELS W732-W760	81	ATTACHMENT COVER GASKET
5*	GEAR SPACER	35	HEX HEAD CAP SCREW	82	ATTACHMENT COVER
6*	OUTPUT BEARING (CONE)	37	OUTPUT SHAFT KEY – MODELS W730-W760	83	HEX HEAD CAP SCREW
7	OUTPUT BEARING (CUP)	43	HORIZONTAL BASE	84	INPUT BEARING (CONE) – MODEL W760 ONLY
9	BEARING CARRIER (OPEN)	44	HEX HEAD CAP SCREW	85	INPUT BEARING (CUP) – MODEL W760 ONLY
10	BEARING CARRIER (CLOSED)	45	LOCKWASHER	86	TWO PIECE FC COUPLING WITH INSERT
11*	OUTPUT OIL SEAL	48	RISER BLOCK	87	MOTOR FLANGE
12*	ADJUSTMENT SHIMS	49	HEX HEAD CAP SCREW	88	HEX HEAD CAP SCREW
13	INTERMEDIATE WORM SHAFT	50	VERTICAL BASE (HIGH OR LOW)	89	MOTOR FLANGE
14	INTERMEDIATE BEARING–MODELS W713-W730	51	HEX HEAD CAP SCREW	90	INPUT WORM SHAFT
15	INTER. BEARING RETAINER–MODELS W732-W760	60	VERTICAL BASE (ASSEMBLY X & Y)	91	EXTERNAL RETAINING RING
16	INTER. OIL SEAL – MODELS W732-W760	63	ATTACHMENT HOUSING	92	OIL SEAL – MODELS FW713-FW738
17	RETAINING RING – MODELS W713-W730	64	INPUT WORM SHAFT	93	WASHER
18	ADJUSTMENT SHIMS	65	INPUT BEARING	165	HOLLOW OUTPUT SHAFT (S VERSION ONLY)
19	BORE PLUG – MODELS W713-W730	66	ADJUSTMENT SHIMS	166	HOLLOW OUTPUT SHAFT (H VERSION ONLY)
21	INTERMEDIATE BEARING	67	RETAINING RING	167	WORM GEAR
22	INTERMEDIATE “O” RING	68	“O” RING	168	OUTPUT BEARING (CONE)
23*	OUTPUT “O” RING	69	BEARING RETAINER	169	OUTPUT BEARING (CUP)
24	HEX HEAD CAP SCREW	70	OIL SEAL	170	OIL SEAL
25	HEX HEAD CAP SCREW	71	HEX HEAD CAP SCREW	171	BEARING CARRIER
26	VENT PLUG – 2 PIECE	72	BORE PLUG – MODELS W713-W738	172	HOLLOW SHAFT MTG. BRACKET
27	PIPE PLUG	73	INPUT WORM SHAFT KEY	173	HEX HEAD CAP SCREW
28	PROTECTIVE CAP PLUG	74	GEAR SPACER	174	LOCKWASHER
29	INTERMEDIATE KEY	75	ADJUSTMENT SHIMS	175	KEY (INTERNAL)
30	OUTPUT KEY	76	HEX HEAD CAP SCREW	176	KEY (EXTERNAL)
		77	INTERMEDIATE WORM GEAR	177	“V” TYPE BASE MODEL (718, 721, 726, 732)
				178	SOCKET SETSCREWS

*For Models 710 to 730, these parts are available as complete assemblies. See Part Ordering Information, Page 10.

Options & Accessories – Double Reduction Models

Hollow Output Shaft Models SW, SFW, and SRFW718-732*

Model 02

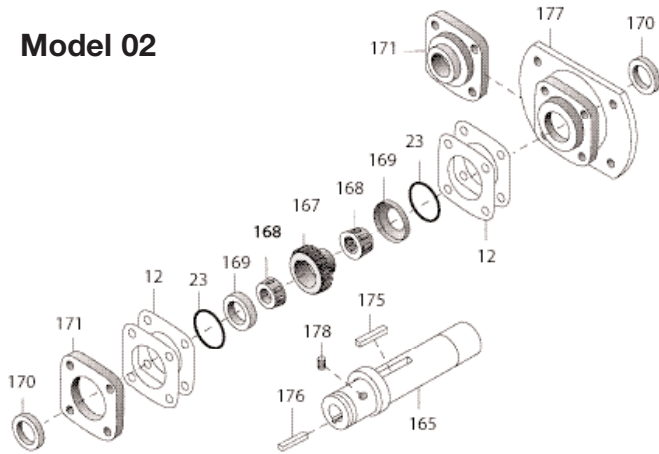

Models W732-W760 Parts added to W732-W760

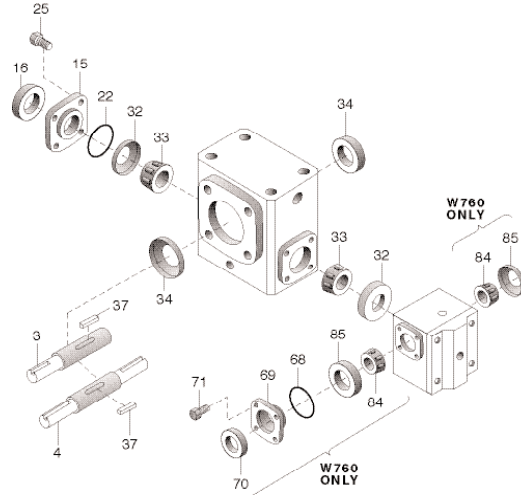

Hollow Output Shaft Models HW, HFW, and HQCW713-738

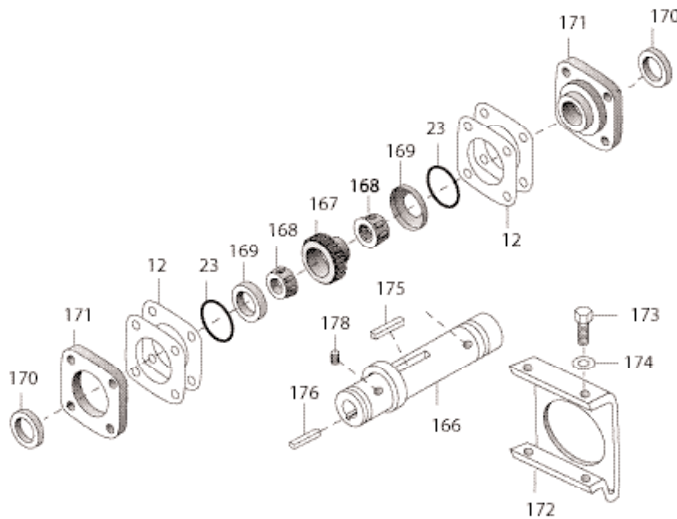

Models FW713-FW752 Parts added to W713-W752

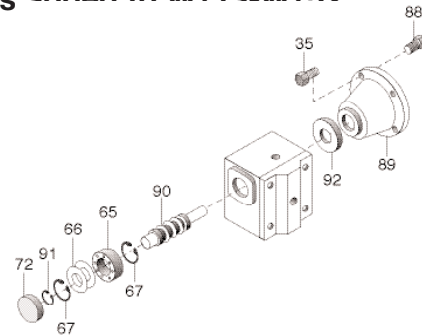

Models QCW713-QCW760 Parts added to W713-W726 or These parts available in kit form.

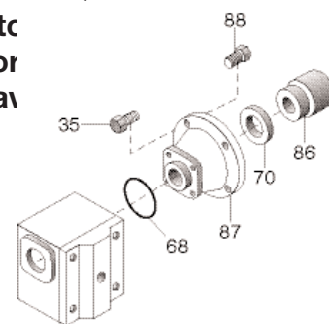

Part ordering information

1. Be sure to provide complete Boston Gear catalog number from speed reducer nameplate, along with part description and number. For example, "One output oil seal, Part No. 11, for W713-150-G".
2. Output shaft components for Boston Gear models 710 through 726 are available only as complete assemblies that include Parts 2, 3, 5, 6, 11, 12 and 23 for single projecting shafts; and Parts 2, 4, 5, 6, 11, 12 and 23 for double projecting shafts. When ordering, specify "output shaft assembly" and full Boston Gear catalog number from nameplate.

* Not available in 730 center distance, see H series.

F700 Series

Disassembly and Reassembly Procedures

(For Item Identification, Refer To Exploded View)

Output Shaft Disassembly

1. Remove vented filler (Item 26), and the most convenient pipe plug (Item 27) and completely drain oil.
2. Remove bearing carrier screws (Item 24) from projecting shaft bearing carrier (Item 9.) Remove carrier by CAREFULLY sliding it over the projecting shaft diameter.
3. Output shaft assembly (Items 2, 3, 5 & 6) can now be removed from the unit. Exercise care not to nick or scratch worm gear or shaft diameters.
4. Visually examine the output shaft assembly. Check tapered roller bearings (Item 6) for signs of metallic contamination or discoloration. Rollers should have continuously smooth action and should not bind or exhibit "flat-spots".
5. Note that replacement parts for output gear (Item 2) will include an output shaft assembly (Items 3 OR 4) for sizes F710 through F726. Also included are items 5, 6, 11, 12 and 23.

Input Shaft Disassembly

Models F710 through F730

1. With a screwdriver or suitable tool, pierce the bore plug (Item 19) and remove from the housing bore.

Models F732 and F738 only

2. Remove fan guard (Item 104.) Remove fan retaining screw (Item 103), fan (Item 101) and spacer. With a screw-driver or suitable tool, pierce and fan end oil seal (Item 16) and remove from the housing bore.
3. Remove the outboard retaining ring (Item 17) from the housing bore. Remove the metal shims (Item 18), located between the retaining ring and the ball bearing (Item 14.)

4. Remove four (4) screws (Item 42) from the motor flange (Item 40) and remove the flange from the housing.
5. Remove the input worm assembly (Items 14, 38 and 39) through the bore opposite the flange side. Remove the oil seal (Item 41) from the housing.
6. Check the condition of the ball bearing (Item 14.) The bearing should roll smoothly and not bind. If the bearing needs replacement, remove the snap ring (Item 38) and press the shaft through the bearing. Install new bearing onto the shaft and re-assemble the snap ring. If the bearing is not pre-packed with grease, pack at least 50% full with Mobilux EP #2 All Purpose Grease or equivalent.

Input Shaft Reassembly

Models F710 through F738

1. Insert input worm assembly in the housing. Seat the ball bearing against the inner retaining ring (Item 17.)
2. Install the metal shims (Item 18) and assemble outboard snap ring (Item 17.)
3. Clean the housing bore(s) in the area where oil seals will be installed.
4. Coat the oil seals as follows:
 - A. Rubber Clad Oil Seals - Apply ALL-PURPOSE grease (NLGI #2 consistency) to the I.D and O.D.
 - B. Steel Clad Oil Seals - Apply ALL-PURPOSE grease to the ID only and coat the bore evenly with Permatex Form-A-Gasket #3 sealant or equivalent.
5. Insert the new oil seal (Item 41) over the shaft until it contacts the housing. CARE MUST BE TAKEN NOT TO DAMAGE THE OIL SEAL LIP.
6. With a small hammer, tap around the face of the oil seal casing - near the outside diameter. Locate the seal as shown in Figure 2 Page 19. Use a suitable driving tool.

Model F710 through F730

7. Install a new bore plug (Item 19.) Coat the bore with PERMATEX FORM-A-GASKET #3 OR EQUIVALENT SEALANT. Using a small hammer, lightly tap around the plug face near the outside diameter. CAUTION should be exercised not to distort or cock the bore plug.

Model F732 and F738

8. Install new oil seal on the fan end (Item 16.) With a small hammer, tap around the face of the oil seal casing - near the outside diameter. Use a suitable tool to assure squareness of the seal to the bore. Drive the seal flush to 1/16th inch projection. Reinstall fan spacer, fan, washer, lockwasher, and bolt. Tighten the bolt per the chart in Figure 5, Page 20. Reinstall the fan guard and tighten the screws per chart in Figure 5.

Worm Gear Replacement

Model F710 through F726

1. Replace the entire output assembly.

Model F730 through F760

2. Place the output gear assembly into a pressing fixture and remove the worm gear from the shaft.
3. With the gear key assembled in the shaft key seal, press the new gear onto the shaft to the dimension shown in Figure 1, Page 19.
4. Install the shaft spacer (Item 5) and grease cups (Item 34.)
5. Press the bearing cones (Item 6) onto the shaft making sure that the assembly is tight (no space between items.)
6. Remeasure from the end of the shaft to the gear face as shown in Figure 1, Page 19. Readjust, if necessary, by pressing on the bearing cone until desired dimension is achieved.
7. Where grease cups are used, pack with Mobilux EP #2 All-purpose grease or equivalent.

Output Shaft reassembly into Housing

1. Remove the existing oil seal (Item 11) from the bearing carrier (Item 9.)
2. Coat the gear teeth with blue or red Dykme mixture or similar coating and install the output assembly into the housing.

3. Slide the bearing carrier over the projecting shaft and bolt the carrier to the housing, making sure the metal shims (Item 12) are between the carrier and the housing. Rotate the input shaft to properly seat the tapered bearings.
4. Shim adjustment must be made at this time. If the output shaft is excessively loose, measure the endplay of the output shaft and remove shims evenly from BOTH carriers until the endplay is within the limits shown in Figure 3, Page 20.

If the carrier does NOT meet the housing face, measure the gap and add shims evenly to BOTH carrier locations until the endplay is within the limits specified.

5. ASSEMBLE THE MOTOR TO THE UNIT. Check the worm gear centrality. Apply a slight load on the output shaft then rotate the input shaft for one to two minutes. Remove the bearing carrier and remove the gear shaft assembly. Check the gear teeth for correct bearing pattern as shown in Figure 6, Page 21.
6. If adjustment is required, all adjustments MUST be made to the carrier which is located on the side OPPOSITE the GEAR HUB. All adjustment for centrality must be made from the TOTAL shim pack which has already been determined.

Example: If a shim is REMOVED from the centralized side, it must be ADDED to the opposite side.

7. When a good bearing pattern has been established, assemble carrier(s) to the unit. Replace all O-rings (Item 23) where required. (Install all shims on the carriers BEFORE installing O-rings.) If replacement O-rings are not available, apply a large bead of Permatex FORM-A-GASKET #3 or equivalent on the pilot diameter and flange.
8. Install a new oil seal (Item 11) into the carrier bore. Use procedures as described above. Press the seal flush to 1/16th inch projecting. Install the carrier over the projecting shaft (recommend placing masking tape over the sharp edges of the shaft keyseat to prevent cutting the oil seal lip.)
9. Tighten all screws as shown in Figure 5, Page 20.
10. Fill the unit to the proper oil level with the recommended lubricant.
11. Install the vent plug (Item 26) and the drain pipe plug (Item 27.)

700 and RF700 Series Flanged

Disassembly and Reassembly Procedures

(For Item Identification, Refer To Exploded View)

Output Shaft Disassembly

1. Remove vented filler (Item 26) and the most convenient pipe plug (Item 27) and completely drain oil.
2. Remove bearing carrier screws (Item 24) from projecting shaft bearing carrier (Item 9.) Remove carrier by CAREFULLY sliding it over the projecting shaft diameter.
3. Output shaft assembly (Items 2, 3, 5 & 6) can now be removed from the unit. Exercise care not to nick or scratch worm gear or shaft diameters.
4. Visually examine the output shaft assembly. Check tapered roller bearings (Item 6) for signs of metallic contamination or discoloration. Rollers should have continuously smooth action and should not bind or exhibit "flat-spots".
5. Note that replacement parts for output gear (Item 2) will include an output shaft (Items 3 OR 4) for sizes RF/710 through RF/726.

Input Shaft Disassembly

Model RF/710 through RF/730

1. With a screwdriver or suitable tool, pierce the bore plug (Item 19) and remove from the housing.
2. Remove the snap ring (Item 17) from the housing. Remove the retainer at the projecting shaft (Item 15) and the shims (Item 18.)
3. With a soft mallet, tap lightly on the projecting shaft, removing the shaft assembly from the bore plug end.
4. Check the condition of the ball bearings (Item 14.) The bearing should roll smoothly and not bind. If the bearing needs replacement, press the shaft through the bearing. Install new bearings on the shaft. Install bearings so that the shields face inward. If the bearing is not prepacked with grease, pack at least 50% full with Mobilux EP #2 All-purpose grease or equivalent.

Model RF/732 through RF/760

5. Remove the fan guard (Item 104.) Remove the fan retaining screw (Item 103), fan (Item 101), and spacer. Remove the retainer(s) (Item 15) at both ends, if applicable or remove the motor flange (Item 47) and shims (Item 18) and O-ring (Item 22.)
6. With a soft mallet, tap lightly on the projecting shaft, removing the bearing cup and input shaft through the fan end.
7. Remove the bearing cup from the projecting shaft end.
8. Check the conditions of the bearing cones and cups (Items 32 and 33.) The rollers should not exhibit pitting. The cage should show no wear or distortion. The bearings, when supported in the cups, should run smoothly with no binding.
9. If the bearings need replacement, press the shaft through the bearing. Hand-pack the new cones with grease and install onto the shafts.

Input Shaft Reassembly

Model RF/710 through RF/730

1. Install the retaining ring (Item 17) in the outboard housing groove. Install the input shaft assembly through the projecting shaft end of the housing. Tap lightly to seat the bearing against the snap ring retainer.
2. Remove the old oil seal (Item 16) from the bearing retainer (Item 15.) Using a small hammer, install a new oil seal by tapping around the face of the seal casing - near the outside diameter. The seal should be flush to 1/16th inch projection above the retainer surface.
3. Install the bearing cup (Item 32) and shims (Item 18), the bearing retainer (Item 15) and the O-ring (Item 22.) If no replacement O-ring is available, apply a heavy bead of PERMATEX FORM-A-GASKET #3 or equivalent in the housing groove and also form a fillet at the retainer pilot diameter and flange. It is recommended to protect the oil seal lip by using masking tape on the keyseat edges.

Model RF/732 through RF/760

4. Install a new oil seal in the far retainer (Item 16.) With a small hammer, tap around the face of the oil seal casing - near the outside diameter. Use a suitable tool to assure squareness of the seal to the bore. Drive the seal flush to 1/16th inch projection.
5. Repack the roller bearings (Items 32 and 33) or replace if required.
6. Reinsert the input shaft assembly, assuring that the far bearing cup (Item 32) is in place. Lightly tap the end of the projecting shaft to seat the bearing.
7. Insert the front bearing cup (Item 32) and the shim pack. Replace the front oil seal in the retainer as per step #4 above.
8. Reinstall the front retainer using the O-ring or Permatex. Tighten all bolts per table Figure 5, Page 20.
9. Rotate the shaft several times to seat the bearings and check for shaft endplay per Figure 4, Page 20. Adjust if required.
10. Replace fan and fan guard. Tighten bolts per Figure 5, Page 20.

Worm Gear Replacement

Model RF/710 through RF/726

1. Replace the entire output assembly.

Model RF/730 through RF/760

2. Place the output gear assembly into a pressing fixture and remove the worm gear from the shaft.
3. With the gear key assembled in the shaft key seat, press the new gear onto the shaft to the dimension shown in Figure 1, Page 19.
4. Install the shaft spacer (Item 5) and grease cups (Item 34.)
5. Press the bearing cones (Item 6) onto the shaft making sure that the assembly is tight (no space between items.)
6. Remeasure from the end of the shaft to the gear face as shown in Figure 1, Page 19. Readjust, if necessary, by pressing on the bearing cone until desired dimension is achieved.

7. Where grease cups are used, pack with Mobilux EP #2 All-purpose grease or equivalent.

Output Shaft Reassembly into Housing

1. Remove the existing oil seal (Item 11) from the bearing carrier (Item 9.)
2. Coat the gear teeth with blue or red Dykme mixture or similar coating and install the output assembly into the housing.
3. Slide the bearing carrier over the projecting shaft and bolt the carrier to the housing, making sure the metal shims (Item 12) are between the carrier and the housing. Rotate the input shaft to properly seat the tapered bearings.
4. Shim adjustment must be made at this time. If the output shaft is excessively loose, measure the endplay of the output shaft and remove shims evenly from BOTH carriers until the endplay is within the limits shown in Figure 4. If the carrier does NOT meet the housing face, measure the gap and add shims evenly to BOTH carrier locations until the endplay is within the limits specified.
5. Check the worm gear centrality. Apply a slight load on the output shaft and rotate the input shaft for one to two minutes. Remove the bearing carrier and remove the gear shaft assembly. Check the gear teeth for correct bearing pattern as shown in Figure 6, Page 21.
6. If adjustment is required, all adjustments MUST be made to the carrier which is located on the side OPPOSITE the GEAR HUB. All adjustment for centrality must be made from the TOTAL shim pack which has already been determined.

Example: If a shim is REMOVED from the centralized side, it must be ADDED to the opposite side.

7. When a good bearing pattern has been established, assemble carrier(s) to the unit. Replace all O-rings (Item 23) where required. (Install all shims on the carriers BEFORE installing O-rings.) If replacement O-rings are not available, apply a large bead of Permatex FORM-A-GASKET #3 or equivalent on the housing face and also form a fillet at the carrier pilot diameter and flange.

8. Install a new oil seal (Item 11) into the carrier bore. Use procedures as described above. Press the seal flush to 1/16th inch projecting. Install the carrier over the projecting shaft (recommend placing masking tape over the sharp edges of the shaft keyseat to prevent cutting the oil seal lip.)
9. Tighten all screws as shown in Figure 5, Page 20.
10. Fill the unit to the proper oil level with the recommended lubricant.
11. Install the vent plug (Item 26) and the drain pipe plug (Item 27.)

FW713 - FW752 Series

Disassembly and Reassembly Procedures

(For item identification, refer to exploded view)

FW713 - FW752 Series

Output Shaft Disassembly

1. Remove vented filler (Item 26), and the most convenient pipe plug (Item 27) and completely drain oil.
2. Remove bearing carrier screws (Item 24) from both bearing carriers (Items 9 & 10.) Remove both carriers.

Note: Carefully slide open carrier (Item 9) over projecting shaft diameter.

3. Output shaft assembly (Items 2, 3, 5 & 6) can now be removed from unit. Exercise care not to nick or scratch worm gear or shaft diameters.
4. Output shaft assembly can now be visually examined. Check tapered roller bearings (Item 6) for signs of any metallic contamination or discoloration. Rollers should have continuously smooth action and should not bind or exhibit “flat-spots”.

Intermediate Worm Shaft Disassembly

Models FW713 - FW730

1. With a screwdriver or other similar tool, pierce input bore plug (Item 19) and remove from housing bore.

Models FW732 - FW752

Remove bearing retainer screws (Item 25) and remove bearing retainer (Item 15.)

Models FW713 - FW752

2. Remove outboard retaining ring (Item 17) from housing bore.

Models FW713 - FW738

3. Remove four (4) screws (Item 83) from attachment cover (Item 82) and remove from housing.
4. Remove screw (Item 80), lock washer (Item 79) and washer (Item 78.)

5. Remove intermediate worm assembly (Item 13) through bore opposite attachment housing.

Models FW713 - FW730

6. Check condition of ball bearings (Items 14 & 21.) Bearings should roll smoothly and not bind. If bearings need replacement, press shaft through bearings. Install new bearings onto shaft. If not already packed with grease, bearings should be packed at least 50% full with Mobilux EP #2 All Purpose Grease or equivalent.

Models FW732 - FW752

Check tapered roller bearings (Items 32 & 33) for signs of any metallic contamination or discoloration. Rollers should have continuously smooth action and should not bind or exhibit “flat-spots”. Repack bearings with Mobilux EP #2 All Purpose or equivalent.

Intermediate Worm Gear

Now that intermediate shaft has been removed, intermediate gear (Item 77) may be removed from attachment housing. Shims (Item 75) and gear spacer (Item 74) should be set aside for reassembly.

Note: Do not attempt to remove intermediate worm gear (Item 77) prior to removal of intermediate shaft as gear teeth will be damaged from being pried out from under the engaged worm threads.

Input Shaft Disassembly

1. With a screwdriver or other similar tool, pierce input bore plug (Item 72) and remove from housing bore.
2. Remove outboard retaining ring (Item 67) from housing bore. Remove metal shims (Item 66) located between snap ring and ball bearing (Item 65.)
3. Remove four (4) screws (Item 88) from motor flange (Item 89) and remove flange from housing.

4. Remove input worm assembly (Item 90) through bore opposite flange side. Remove oil seal (Item 92) from housing bore. Inboard retaining ring (Item 67) will remain in housing.
5. Check condition of ball bearing (Item 65.) Bearing should roll smoothly and not bind. If bearings need replacement, remove snap ring (Item 91) and press shaft through bearing.

Install new bearing onto shaft and reassemble snap ring (Item 91.) If not already packed with grease, bearing should be packed at least 50% full with Mobilux EP #2 All Purpose Grease or equivalent.

Input Shaft Reassembly

1. Insert input worm shaft assembly (Item 90) into housing with retaining ring (Item 67) used to seat ball bearing.
2. Install metal shims (Item 66) and assemble outboard snap ring (Item 67.)
3. Clean housing bore(s) in area where oil seal is to be inserted.
4. Oil Seal Assembly:
 - A. Rubber Clad Oil Seal

Apply All Purpose Grease (NLGI #2 consistency) to I.D. and O.D.
 - B. Steel Clad Oil seal

Lightly apply All Purpose Grease to I.D. only and coat bore evenly with Permatex "Aviation FORM-A-GASKET" #3 or equivalent.
5. Insert new oil seal (Item 92) over the shaft (care must be taken not to damage oil seal lip) until it contacts the housing.
6. With small hammer, tap around the face of seal casing near the outside diameter. Oil seal location as follows:

Flange end oil seal - Refer to Figure (2) Page 19 (use suitable driving tool to recess seal.)
7. Install new bore plug (Item 72.) Coat bore with PERMATEX "Aviation FORM-A-GASKET" #3 or equivalent sealant. If rubber clad O.D. no sealant is required. Using small hammer, lightly tap around plug face near the outside diameter. Caution should be exercised not to distort or cock plug during installation.
8. Assemble motor flange (Item 89.)

Intermediate Worm Reassembly

1. Insert intermediate worm assembly (Item 13) through bore opposite attachment housing.

Note: Spacer (Item 74) and shims (Item 75) should be put on shaft and worm gear (Item 77) held in mesh with input worm (Item 90) while sliding intermediate worm assembly into position.

2. Assemble attachment cover (Item 82)

Models FW713 - FW730

3. Install new bore plug (Item 19.) Coat bore with PERMATEX "Aviation FORM-A-GASKET" #3 or equivalent sealant. If rubber clad O.D. no sealant is required. Using small hammer, lightly tap around plug face near the outside diameter. Caution should be exercised not to distort or cock plug during installation.

Models FW732 - FW752

Assemble intermediate bearing retainer (Item 15.)

Worm Gear Replacement

Models FW713 - FW726

1. Replace entire output assembly.

Models FW730 - FW752

1. Place output gear assembly (Item 2) into a pressing fixture and remove worm gear from shaft.
2. With gear key assembled in shaft keyseat, press new gear onto shaft to dimension shown in Figure 1, Page 19.
3. Install shaft spacer (Item 5) and grease cups (Item 34) when applicable.
4. Press bearing cones (Item 6) onto shaft making sure the assembly is tight.
5. Remeasure from end of shaft to worm gear face as shown in Figure 1, Page 19. If adjustment is necessary, press bearing cone (Item 6) until required dimension is achieved.
6. Where grease cups are used, pack with Mobilux EP #2 All Purpose Grease or equivalent.

Output Shaft Reassembly into Housing

1. Remove existing oil seal (Item 11) from bearing carrier (Item 9.)
2. Coat gear teeth (Item 3) with red-lead mixture or similar coating and install output gear assembly into housing.
3. Slide bearing carrier (Item 9) over projecting shaft (Item 4) diameter and bolt carrier to housing. Make sure metal shims (Item 12) are between carrier and housing face. Rotate input shaft to properly seat tapered roller bearings.
4. Adjustments of shims (Item 12) must be made at this time. If output shaft is excessively loose, measure endplay of output shaft and remove shims (Item 12) evenly from both carriers (Items 9 and 10) until endplay is within limits specified on Figures 3 or 4, Page 20.

If bearing carrier (Item 9) does not meet housing face, measure gap and add shims (Item 12) evenly to each side (Items 9 and 10.)

5. Assemble motor to unit. Check worm gear centrality. Apply slight load to output shaft and rotate input shaft for 1 or 2 minutes. Remove output bearing carrier (Item 9) and remove output gear assembly. Check gear teeth for bearing pattern. Optimum bearing pattern is shown in Figure 3.

If gear requires adjustment for centrality, all adjustments must be made from side opposite gear hub.

Note: All adjustment for gear centrality to be made from the already established total shim pack (Ref. - Step 4.) For example - If a shim is removed from centralized side, it must be added to the opposite side.

6. When good bearing pattern or gear teeth is established, assemble carriers(s) to unit. Apply PERMATEX "Aviation FORM-A-GASKET" #3 or equivalent sealant to form fillet at pilot diameter of carrier. Install new oil seal (Item 12) into bearing carrier bore. Seal assembly same as shown in "Input Shaft Reassembly" - Steps 4, 5 and 6. (Recommend masking tape over sharp keyseat edges so seal lip is not cut or damaged.) Oil seal to be flush with carrier face.

7. Fill unit to proper level with recommended gear lubrication. Ref. Page 5.

8. Install vent (Item 26) and pipe plug (Item 27.)

Important: All screw tightening torques listed in Figure 5, Page 20.

Note: For RFW and W700 Series Ref. to Single Reduction Instructions for 700/RF Series Input Disassembly and reassembly Page 13.

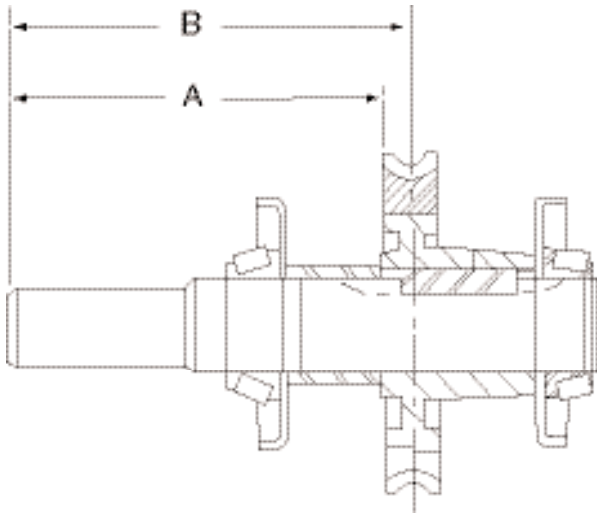

Unit	"A" ± 1/64	"B" Ref. Only
730	6.310	6-3/4
732	7.469	7-1/16
738	7.25	7-3/4
752	8.44	9-1/16
760	9.28	10

Figure No. 1

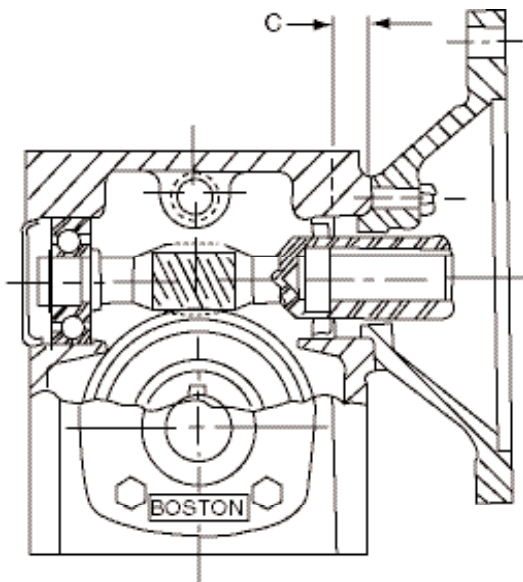

Unit Size	"C" Dimension
F710/FW713 FW718	5/16
F713/FW721 FW726	3/8
F715	3/8
F718/FW732	3/8
F721/FW738	3/8
F724	3/8
F726	3/8
F730	3/8
F732	5/8
F738	5/8

Figure No. 2

Note: "C" Dimensions shown are original oil seal locations. When seal is replaced add or subtract 1/16th of an inch to dimension shown. This will allow seal to wear on a new surface for extended life.

ENDPLAY - FLANGED REDUCTOR

UNIT SIZE	INPUT SHAFT ENDPLAY	OUTPUT SHAFT ENDPLAY
F710, F713	Free Running to .0075 Max.	Free Running to .003 Max.
F715 Through F730	Free Running to .009 Max.	Free Running to .003 Max.
F732 Through F738	Free Running to .003 Max.	Free Running to .003 Max.

Figure No. 3

ENDPLAY - REDUCTOR & RF TYPE

UNIT SIZE	INPUT SHAFT ENDPLAY	OUTPUT SHAFT ENDPLAY
710, 713	Free Running to .002 Max.	Free Running to .003 Max.
715 Through 730	Free Running to .003 Max.	Free Running to .003 Max.
732 Through 738	Free Running to .005 Max.	Free Running to .003 Max.

Figure No. 4

Note: Endplays adjusted by -

1. Input Shaft - Adding or subtracting metal shims (Item 18)
2. Output Shaft - Adding or subtracting metal shims (Item 12)

SCREW TIGHTENING TORQUES (IN-LBS.)

UNIT SIZE	CARRIER SCREW	FLANGE SCREW	FAN GUARD SCREW	FAN ATTACH. SCREW	PIPE PLUG
F710	40-65	45-65			90
F713	132-156	132-156			132
F715	264-312	264-312			132
F718	264-312	264-312			132
F721	264-312	264-312			132
F724	264-312	264-312			132
F726	264-312	264-312			132
F730	264-312	264-312			132
F732	264-312	264-312	85-105	140-160	240
F738	480-552	264-312	85-105	140-160	240
F752	840-948	840-948	132-156	140-160	240
F760	1200-1368	840-948	132-156	140-160	240

Figure No. 5

IDEAL POSITIONING OF WORM GEAR CONTACT

Figure No. 6

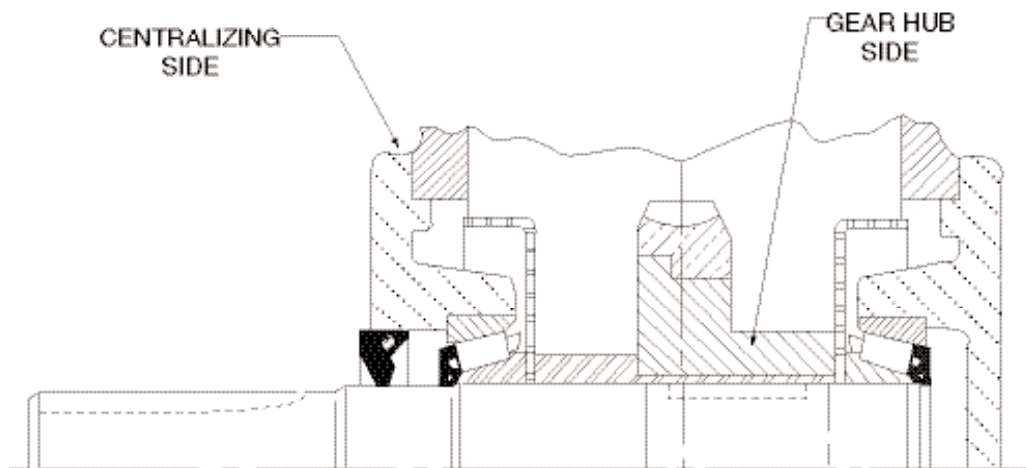
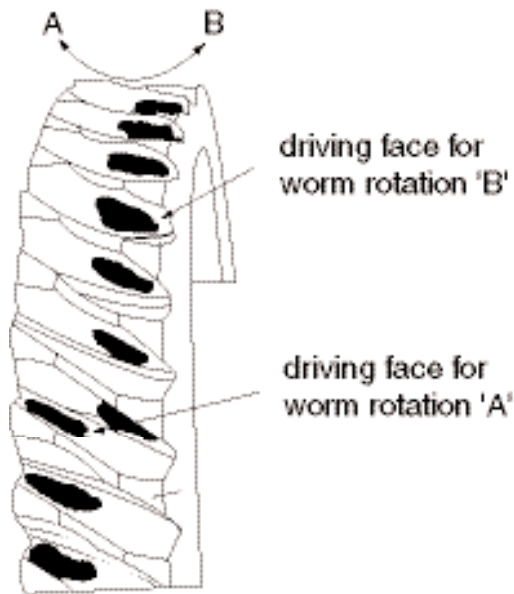
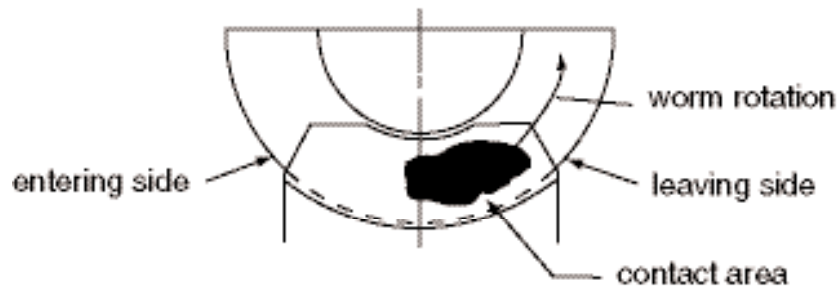

700 Series Single Reduction Catalog Number Explanation

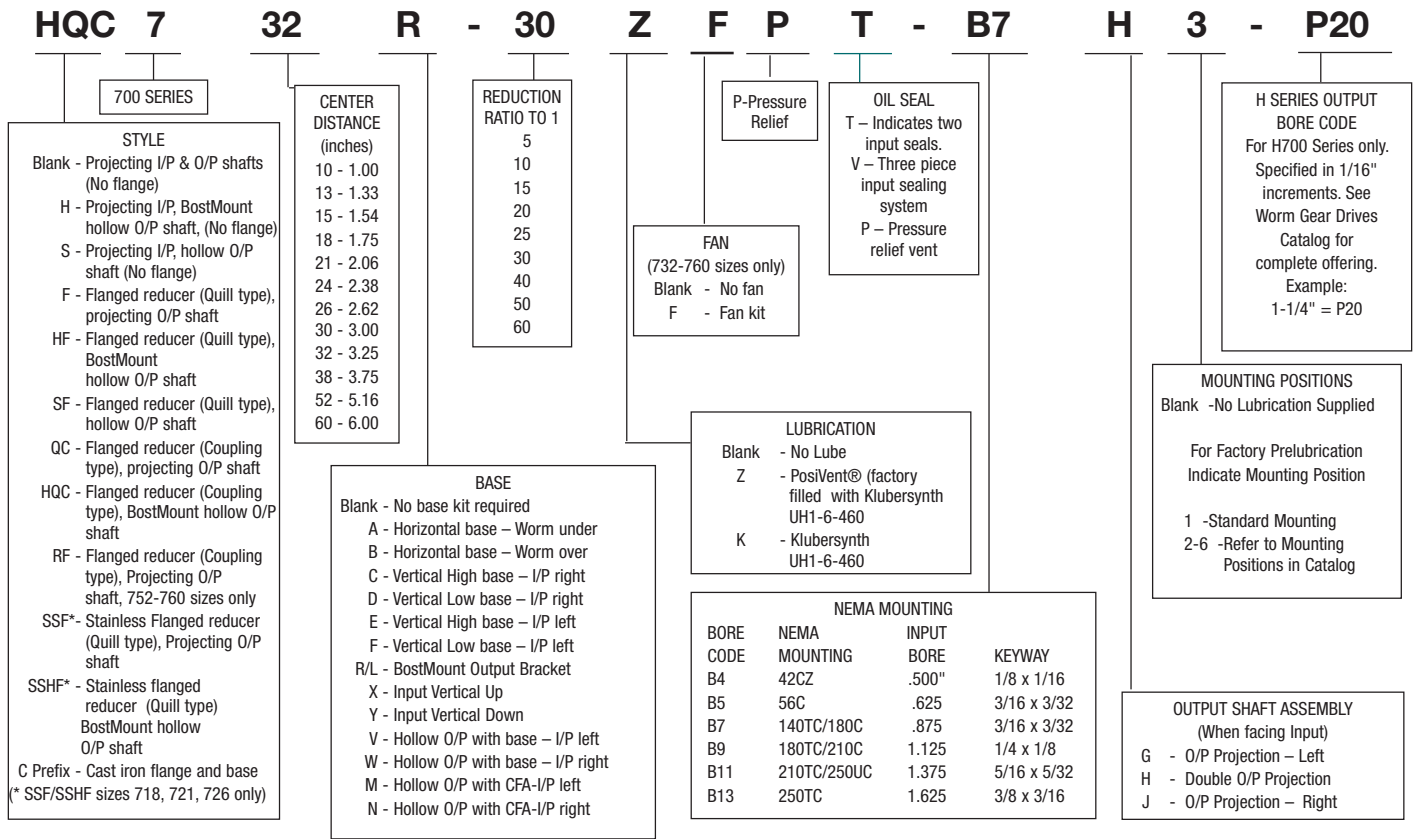

700 Series Double Reduction Catalog Number Explanation

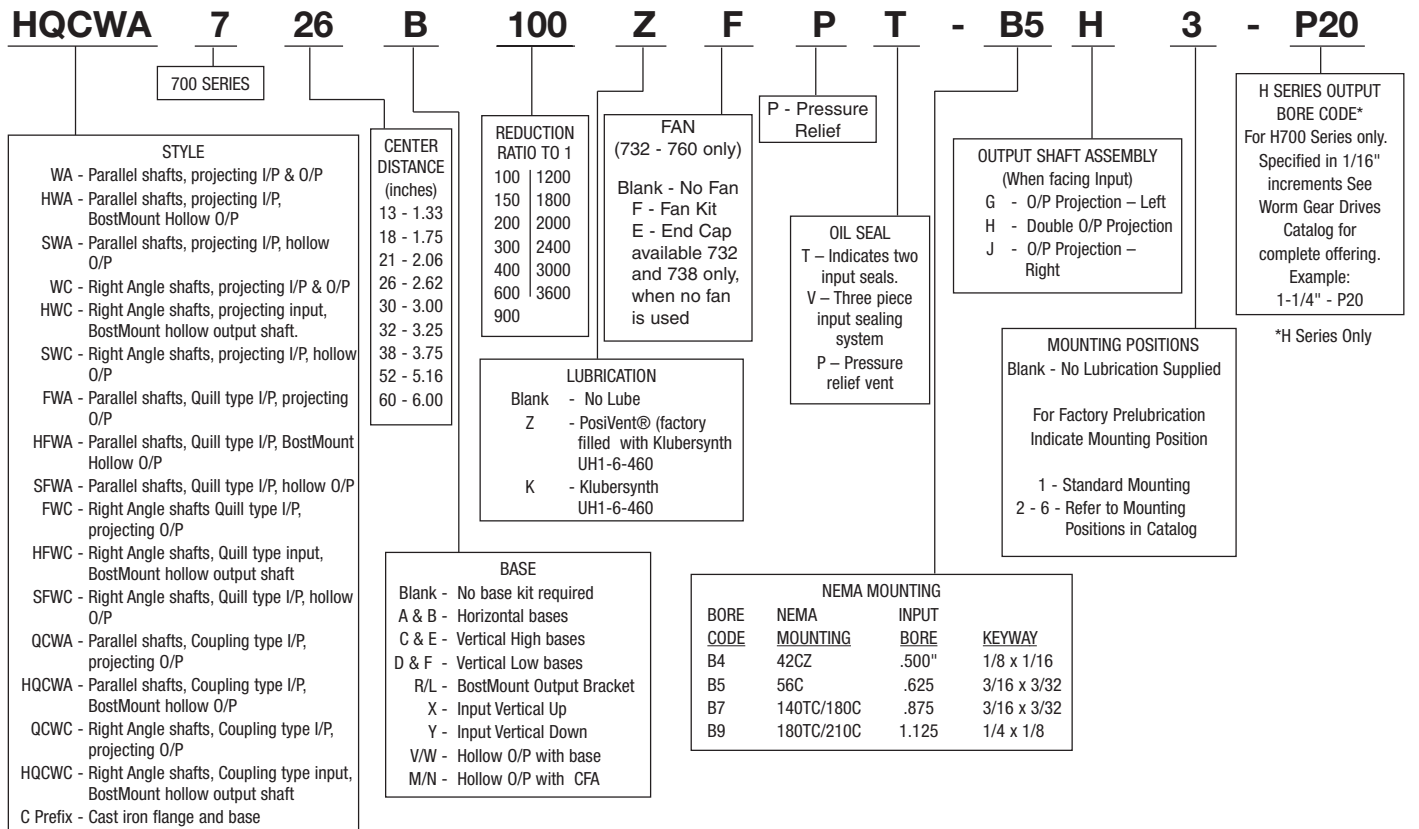

Note: Contact factory for other model numbers.

Warranty

The Company warrants that all 700 Series speed reducers will be free from defects in material and workmanship over the lifetime of the product.

Oil seals are considered to be replaceable maintenance items.

Any products which shall be proved to the Company's satisfaction to have been defective at the time of delivery in these respects will be replaced or repaired by the Company at its option. Freight is the responsibility of the customer. The Company's liability under this warranty is limited to such replacement or repair and it shall not be held liable in any form of action for direct or consequential damages to property or person. THE FOREGOING WARRANTY IS EXPRESSLY MADE IN LIEU OF ALL OTHER WARRANTIES WHATSOEVER, EXPRESS, IMPLIED AND STATUTORY AND INCLUDING WITHOUT LIMITATION THE IMPLIED WARRANTIES OF MERCHANTABILITY AND FITNESS. No employee, agent, distributor, or other person is authorized to give additional warranties on behalf of Boston Gear, nor to assume for Boston Gear any other liability in connection with any of its products, except an officer of Boston Gear by a signed writing.



Boston Gear
14 Hayward Street, Quincy, MA 02171
617.328.3300 fax 617.479.623
www.bostongear.com
a division of *Altra Industrial Motion*