

ISO VIEW

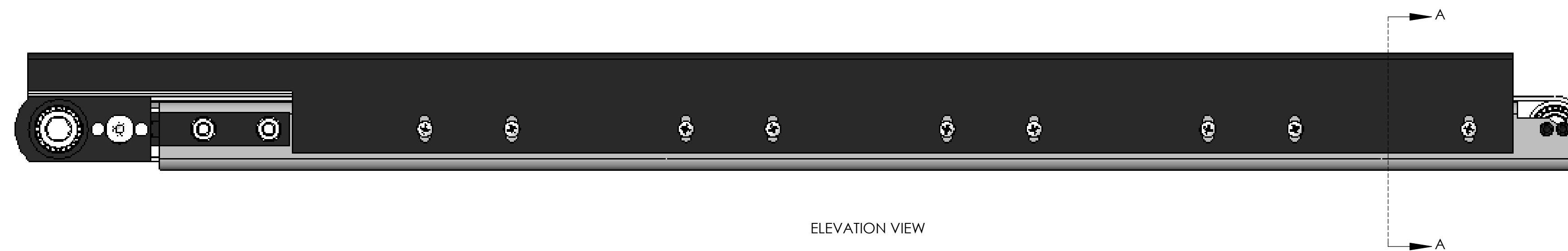

ELEVATION VIEW

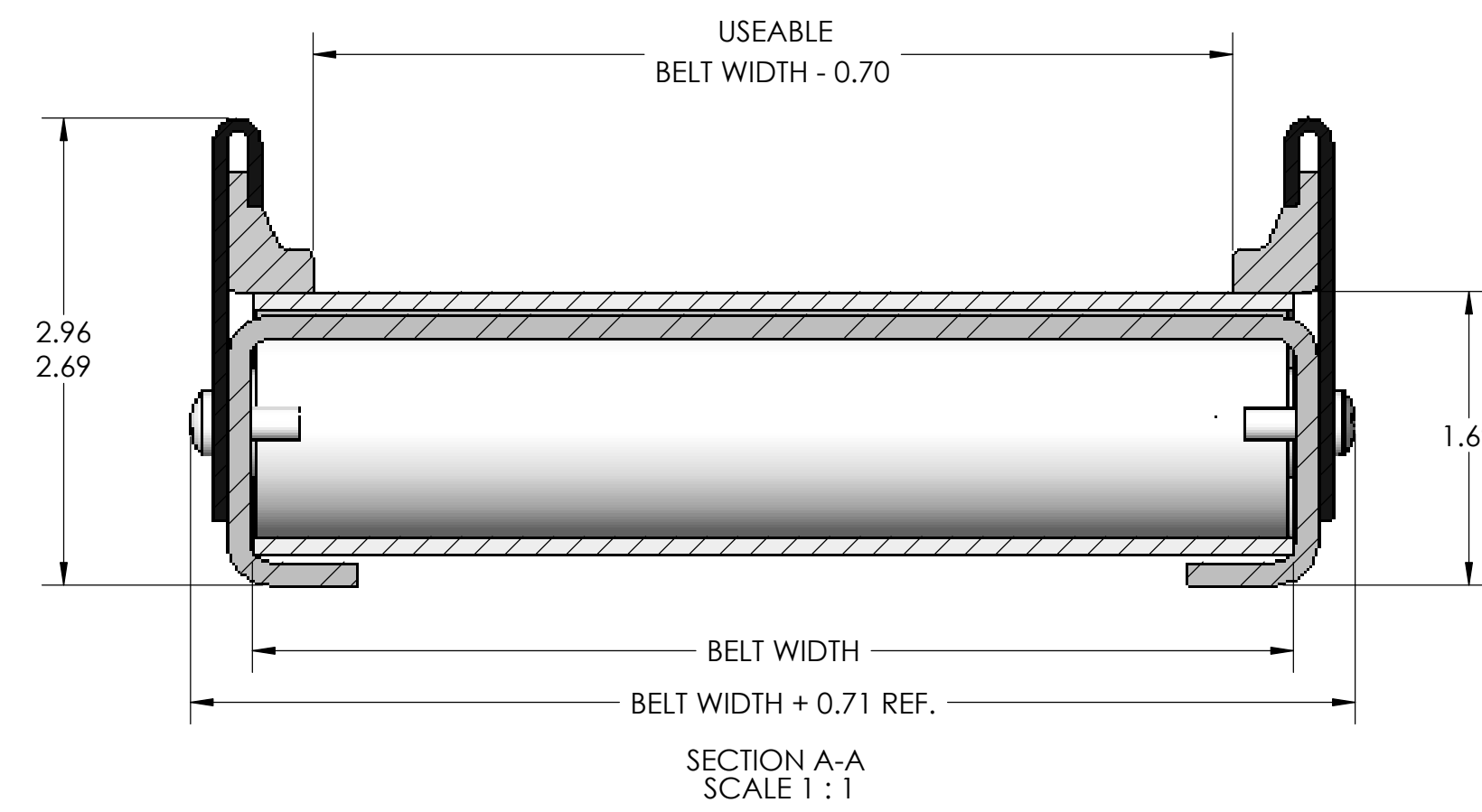

PROPRIETARY AND CONFIDENTIAL
THE INFORMATION CONTAINED IN THIS
DRAWING IS THE SOLE PROPERTY OF
WARDCRAFT CONVEYOR. ANY
REPRODUCTION IN PART OR AS A WHOLE
WITHOUT THE WRITTEN PERMISSION OF
WARDCRAFT CONVEYOR IS
PROHIBITED.

1897
WARDCRAFT
Div. of McLaughlin Ward & Co.
SPRING ARBOR, MI 49283
PHONE: (800) 765-2719 FAX: (419) 765-2244
www.wardcraftconveyor.com

UNLESS OTHERWISE SPECIFIED:		NAME	DATE
DIMENSIONS ARE IN INCHES		G.W.C.	09-07-05
TOLERANCES:			
FRACTIONAL 1/16			
ANGULAR MACH 1:1 BEND ±1°			
TWO PLACE DECIMAL ±0.010			
THREE PLACE DECIMAL ±0.005			
INTERPRET GEOMETRIC TOLERANCING PER:			
MATERIAL			
FINISH			
DRAWN			
CHECKED			
ENG APPR:			
MFG APPR:			
Q.A.			
COMMENTS:			

MODULAR SLUG-VAYOR		
TITLE: 1" HIGH SIDE WITH WIPERS		
SIZE D	DWG. NO. HS03	REV
SCALE: 1:2	WEIGHT:	SHEET 1 OF 1