

AM SERIES LUBRICATED AIR MOTORS

OPERATION & MAINTENANCE MANUAL



Model 2AM Shown



Model 4AM Shown

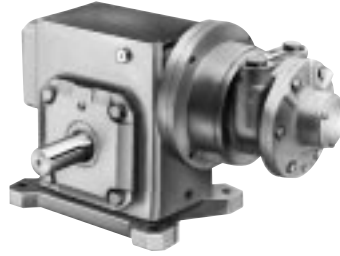

Model 6AM Shown



Model 16AM Shown

Thank you for purchasing this Gast product. It is manufactured to the highest standards using quality materials. **This manual includes general safety instructions for operation under normal conditions and for operation in hazardous conditions.** Please follow all recommended maintenance, operational and safety instructions and you will receive years of trouble free service.

IMPORTANT: PLEASE READ THIS MANUAL COMPLETELY BEFORE INSTALLING AND USING THIS MOTOR. SAVE THIS MANUAL FOR FUTURE REFERENCE AND KEEP IN THE VICINITY OF THE MOTOR.

General information

Operating Pressure Limits:

Model	Pressure
1AM	100 PSI / 7 bar
1 UP	80 PSI / 5.6 bar
2 AM	100 PSI / 7 bar
4 AM	100 PSI / 7 bar
6 AM	100 PSI / 7 bar
8 AM	100 PSI / 7 bar
16 AM	100 PSI / 7 bar

Vane Life: Depends upon speed, operating pressure and motor maintenance. In normal operating conditions inspect vanes after 5,000 to 8,000 hours of operation.

Product Use Criteria:

- Normal conditions: Operate at temperatures up to 250°F (121°C).
- Hazardous conditions: Operate at temperatures up to 104°F (40°C).
- Protect unit from dirt and moisture.
- Use ONLY compressed air to drive motor.
- Air lines connected to motor should be the same size or the next size larger than the inlet port for efficient output and speed control.
- Protect all surrounding items from exhaust air.
- Bearings are grease packed.
- Use Gast #AD220 or a detergent SAE#10 automotive engine oil for lubricating.

- Motors are to be used in commercial installations only.
-  **This symbol appears on labels of air motors that are designed for use in hazardous atmospheres. These air motors comply with the applicable standards and specifications and meet the requirements of the guidelines of the EC directive 94/9EC (ATEX 100a). They are intended to be used in zones 1 and 2 where explosive atmospheres are likely to occur.**
- Air supply, directional control valve and pressure regulator should be selected based upon the air consumption of the motor.



ISO 9001 & 14001 CERTIFIED

www.gastmfg.com

Your safety and the safety of others is extremely important.

We have provided many important safety messages in this manual and on your product. Always read and obey all safety messages.



This is the safety alert symbol. This symbol alerts you to hazards that can kill or hurt you and others. The safety alert symbol and the words "DANGER" and "WARNING" will precede all safety messages. These words mean:

DANGER

You will be killed or seriously injured if you don't follow instructions.

WARNING

You can be killed or seriously injured if you don't follow instructions.

All safety messages will identify the hazard, tell you how to reduce the chance of injury, and tell you what can happen if the safety instructions are not followed.

CODE SYMBOLS



Hazard. Possible consequences: death or severe injuries.



Hazardous situation. Possible consequences: slight or mild injuries.



Dangerous situation. Possible consequences: damage to the drive or the environment.



Important instructions on protection against explosion.



Application tips and useful information.

Improper environment, installation and operation can result in severe personal injury and/or damage to property.

Qualified personnel must perform all work to assemble, install, operate, maintain and repair air motor.

Qualified personnel must follow:

- These instructions and the warning and information labels on the motor.
- All other drive configuration documents, startup instructions and circuit diagrams.
- The system specific legal regulations and requirements.
- The current applicable national and regional specifications regarding explosion protection, safety and accident prevention.



Complete the following checklist prior to starting installation in a hazardous area. All actions must be completed in accordance with ATEX 100a.

Checklist for installation in hazardous areas:

_____ Read air motor label to check that motor has been designed for use in a hazardous application:

- Hazardous zone
- Hazardous category
- Equipment group
- Temperature class
- Maximum surface temperatures

Example:

Model designation: 1UP-NRV-10

Year manufactured: 2003

 Gast Mfg. Corp.

II 2GD c T5 *

Benton Harbor, MI USA

Telephone: 269.926.6171

* Legend:

II Equipment group II

2 Equipment category 2

G Gas atmospheres

D Dust atmospheres

c Constructional safety

T5 Max. surface temp. 212°F/100°C

_____ Check the site environment for potentially explosive oils, acids, gases, vapors or radiation

_____ Check the ambient temperature of the site and the ability to maintain proper ambient temperature.

Ambient range:

Normal conditions: 34°F/1°C to 250°F/121°C

Hazardous conditions: 34°F/1°C to 104°F/40°C

_____ Check the site to make sure that the air motor will be adequately ventilated and that there is no external heat input (e.g. couplings). The cooling air may not exceed 104°F/40°C.

_____ Check that products to be driven by the air motor meet ATEX approval.

_____ Check that the air motor is not damaged.

INSTALLATION

Correct installation is your responsibility. Make sure you have the proper installation conditions.



WARNING

Injury Hazard

Install proper guards around output shaft as needed.

Air stream from product may contain solid or liquid materials that can result in eye or skin damage.

Wear eye protection when installing this product.

Failure to follow these instructions can result in serious injury or property damage.

Mounting

This product can be installed in any orientation. Mount the motor to a solid metal base plate that is mounted to a stable, rigid operating surface. Use shock mounts to reduce noise and vibration. Install a pressure regulator or simple shut-off valve to control motor.

Connection

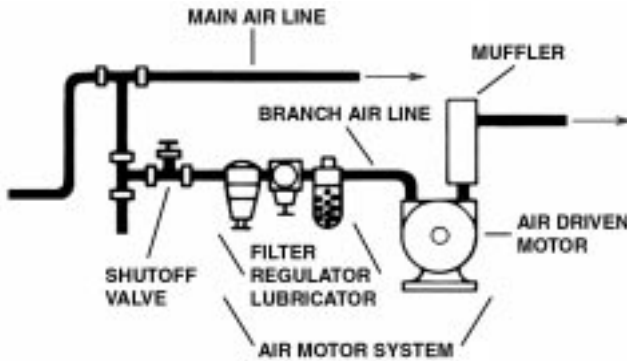

Check the direction of the motor airflow. A single rotation motor will operate properly only in one direction. Single rotation motors require a sound absorber to be connected to the air port. Remove the plastic shipping plugs from the ports. Save plugs for future use during shutdown.

Install a 5-micron filter in the air line before the connection to the motor. Next install an air pressure regulator to control motor speed and torque.

An automatic air line lubricator should be installed in the air line as close as possible and no more than 18 inches (1/2 meter) from the air motor. Install the lubricator level with or above the air motor so that the oil mist will blow directly into or fall down into the motor.

Fill the oil reservoir to the proper level with Gast #AD220 or SAE 10W high detergent or non-detergent motor oil. For food processing applications, White Rex 425 food grade motor oil is FDA approved. Adjust lubricator to feed 1 drop of oil for every 50 CFM of air while the unit is running, or 1 drop of oil per continuous minute of run time. Do Not overfeed oil or exhaust air may become contaminated.

Clean the compressed air connection with low pressure air to remove any dirt from the line before connecting to the ports.

Use the proper sized fasteners. For the most efficient output and control of speed, use air lines that are the same size as the motor inlet port if the connection is less than 7 feet (2 meters). For longer connections, use the next pipe size larger than the motor intake port. Connect lines to motor in the proper direction.

A reversible motor will work equally well in both directions. Connect a 4-way valve with piping to both air ports of motor to make reversing possible. Connect the sound absorber on the exhaust air port or valve connection.

Do not add any thrust to the end or side of the shaft when making connections.



Do not use a hammer on the shaft or connections.



Lubricating the drive shaft will make assembly easier. Use a puller for removal of pulleys, couplings and pinions on the motor shaft. Check that the tension on the belt pulley matches the manufacturer's specifications. Do not exceed the maximum radial and axial forces on the shaft. If the motor shaft is connected to the part to be driven without a coupling, check that the radial offset and axial force effect will not cause problems.



Use only belts with <math>< 10^9</math> electrical leakage resistance to prevent static electrical problems.

Accessories

A muffler is shipped with the air motor (except 16AM) but is not installed. Consult your Gast Distributor/Representative for additional filter recommendations. Install a moisture trap and 5 micron filter in the air line ahead of motor.

Air consumption data at various speeds and pressures are available from your Gast Distributor/Representative or the factory.

OPERATION



WARNING

Injury Hazard

Air stream from product may contain solid or liquid material that can result in eye or skin damage.

Do Not use combustible gases to drive this motor.

Wear hearing protection. Sound level from motor may exceed 85 db (A).

Failure to follow these instructions can result in eye injury or other serious injury.

Check all connections before starting motor. It is your responsibility to operate this product at recommended speeds, loads and room ambient temperatures. Do not run the motor at high speeds with no load. This will result in excessive internal heat that may cause motor damage.

The starting torque is less than the running torque. The starting torque will vary depending upon the position of the vanes when stopped in relation to the air intake port.

Use a pressure regulator and/or simple shut-off valve to regulate the motor's speed and torque. This will provide the required power and will conserve air. Open the air supply valve to the motor. Set the pressure or flow rate to the required speed or torque. Adjust the lubricator to feed one drop of oil for every 50-75 CFM (1.5-2 M³ per minute) of air moving through motor. Check the oil level daily. The gear reducer does not need lubrication.



Operate the motor for approximately 2 hours at the maximum desired load. Measure the surface temperature of the motor on the casting opposite the pipe ports. The maximum surface temperature listed on the motor is for normal environmental and installation conditions. For most air motors, the maximum surface temperature should not exceed 203°F/95°C. Do not continue to operate the motor if the measured surface temperature exceeds temperature listed on the motor. If your measured temperature does exceed listed value, consult with your Gast Distributor/Representative for a recommendation.

MAINTENANCE



WARNING

Injury Hazard

Disconnect air supply and vent all air lines.
Wear eye protection when flushing this product.
Air stream from product may contain solid or liquid material that can result in eye or skin damage.
Flush this product in a well ventilated area.
Do Not use kerosene or other combustible solvents to flush this product.
Failure to follow these instructions can result in eye injury or other serious injury.

It is your responsibility to regularly inspect and make necessary repairs to this product in order to maintain proper operation.

Lubrication

Use Gast #AD220 or a detergent SAE #10 automotive engine oil for lubricating. Lubricating is necessary to prevent rust on all moving parts. Excessive moisture in air line may cause rust or ice to form in the muffler when air expands as it passes through the motor. Install a moisture separator in the air line and an after cooler between compressor and air receiver to help prevent moisture problems.

Manual Lubrication

Shut the air motor down and oil after every 8 hours of operation. Add 10-20 drops of oil to the air motor intake port.

Automatic Lubrication

Adjust inline oiler to feed 1 drop of oil per minute for high speed or continuous duty usage. Do Not overfeed oil or exhaust air may become contaminated.

Check intake and exhaust filters after first 500 hours of operation. Clean filters and determine how frequently filters should be checked during future operation. This one procedure will help assure the motor's performance and service life.

Flushing

Flushing this product to remove excessive dirt, foreign particles, moisture or oil that occurs in the operating environment will help to maintain proper vane performance. Flush the motor if it is operating slowly or inefficiently.

Use only Gast #AH255B Flushing Solvent. DO NOT use kerosene or ANY other combustible solvents to flush this product.

1. Disconnect air line and muffler.
2. Add flushing solvent directly into motor. If using liquid solvent, pour several tablespoons directly into the intake port. If using Gast #AH255B, spray solvent for 5-10 seconds into intake port.
3. Rotate the shaft by hand in both directions for a few minutes.
4. **You must wear eye protection for this step.** Cover exhaust with a cloth and reconnect the air line.
5. Restart the motor at a low pressure of approximately 10 PSI/0.7 bar until there is no trace of solvent in the exhaust air.
6. Listen for changes in the sound of the motor. If motor sounds smooth, you are finished. If motor does not sound like it is running smoothly, installing a service kit will be required (See "Service Kit Installation").



Check that all external accessories such as relief valves or gauges are attached and are not damaged before operating product.

Cleaning sound absorber

1. Remove the sound absorber.
2. Clean the felt filter.
3. **You must wear eye protection for this step.** Lubricate motor with 3-4 drops of oil.
4. Check the air compressor.
5. Listen for changes in the sound of the motor. If motor sounds smooth, you are finished. If motor does not sound like it running smoothly, installing a service kit will be required (See "Service Kit Installation").

Shutdown

It is your responsibility to follow proper shutdown procedures to prevent product damage.

1. Turn off air intake supply.
2. Disconnect air supply and vent all air lines.
3. Disconnect air lines.
4. Remove air motor from connecting machinery.
5. Remove the muffler.
6.   **Wear eye protection. Keep away from air stream.** Use clean, dry air to remove condensation from the inlet port of the motor.
7. Lubricate motor with a small amount of oil into the intake port. Rotate shaft by hand several times to distribute oil.
8. Plug or cap each port.
9. Coat output shaft with oil or grease.
10. Store motor in a dry environment.

SERVICE KIT INSTALLATION

Gast will NOT guarantee field-rebuilt product performance. For performance guarantee, the product must be returned to a Gast Authorized Service Facility.

Service Kit contents vary. Most contain vanes, end cap gasket, body gasket, bearings and a muffler element or felt.

Major and Minor Rebuilds

Tool kits which include a more in-depth rebuild manual are available through your Gast Distributor/Representative. These kits include the tools required to remove and reassemble end plates, bearings and shaft seals, and to set the proper end clearance. The rebuild manual also includes step by step instructions, including illustrations, to help achieve a successful rebuild. Gast Manufacturing, Inc. highly recommends using the air motor rebuild manual and tool kit when attempting a minor or major rebuild to your Gast air motor.

Minor Rebuild:

1. Remove the end cap.
2. Remove dead end plate bolts.
3. Remove dead end plate. (Use factory issued tool, do not use screwdriver to remove the end plate.)
4. Remove the dowel pins from the body and push back into end plate until flush or just below the machined surface of the end plate.
5. Remove vanes.
6. Clean parts. Check for scoring on the end plate and rotor assembly. If scoring exists, send unit to a Gast authorized service facility.
7. **Lubricated models only:** Lightly oil and reinstall vanes.
8. Place the proper end plate gasket on the end plate. If the original is damaged, replace with a new one supplied in the Service Kit.
9. Place the dead end plate on the body.
10. Press the bearing onto the shaft using a factory supplied bearing pusher.
11. Tap dowel pins into body and install end plate bolts. Tighten bolts to 75-100 in-lbs.
12. Set end clearance as required by model:
1AM-4AM and NL22-NL52 models - use the bearing taper from kit to lightly tap on inner race of the dead end bearing to free up and center the rotor in the body.
6AM-8AM models - lightly strike the drive end shaft with a soft hammer to push the rotor away from the drive end plate. The rotor must NOT rub on either end plate.
13. Reattach end cap.
14. **If the air motor is lubricated**, apply a few drops of Gast #AD220 lubricant into ports. Rotate shaft by hand for a few rotations.

Major Rebuild:

1. Remove the end cap.
2. Remove dead end plate bolts.
3. Remove dead end plate. (Use factory issued tool, do not use screwdriver to remove the end plate.)
4. Remove the dowel pins from the body and push back into end plate until flush or just below the machined surface of the dead end plate.
5. Remove rotor using an arbor press.

6. Remove vanes and ejection mechanism if reversible. (Ejection mechanisms may consist of vane springs, pins, caps or cam rings.)
7. Remove shaft seal and bearings from drive end plate and bearing from dead end plate. (Use factory issued tool.)
8. Do Not remove drive end plate bolts or drive end plate.
9. Clean parts. Check for scoring on the end plates and rotor assembly. If scoring exists, send unit to a Gast Authorized Service Facility.
10. **For reversible models only:**
1AM and 1UP models - place a new cam ring between the rotor and the drive end plate.
2AM and 4AM models - place springs and caps in rotor.
6AM, 8AM and 16AM models - install push pins.
11. Place the drive shaft of the rotor assembly through the drive end plate. Press the drive bearing onto the drive shaft using a factory supplied bearing pusher.
12. Using the bearing taper from the Tool Kit, lightly tap on inner race of the drive end bearing to snug up rotor to drive end plate.
13. Install new vanes as required by model:
All single rotation units - the angle cuts on the vane face to center of the rotor.
Reversible units 2AM and 4AM - the notch on vane faces to center of the rotor.
6AM, 8AM and 16AM models - install the vane spring lip into the notch at one end of the vane and place in rotor vane slot with spring facing pushpin.
14. Place the proper end plate gasket on the body of dead end. If the original is damaged, replace with a new one supplied in the service kit. If your air motor uses O-rings, place the new O-rings in the body groove. Some models do not use end plate gaskets or O-rings.
15. Place the dead end plate on the body.
16. Install the dead end bearing and press into place with bearing pusher tool from tool kit.
17. Install the dowel pins.
18. Fully tighten the remaining bolts to 75-100 in-lbs.
19. Set end clearance as required by model:
1AM-4AM and NL22-NL52 models - use the bearing taper from the Tool Kit and lightly tap on the inner race of the dead end bearing to free up and center the rotor in the body.
6AM-8AM models - lightly strike the drive end shaft with a soft hammer to push the rotor away from the drive end plate. The rotor must NOT rub on either end plate.
20. Apply a small amount of grease to bearing seal and install the drive end bearing seal by pressing flush with bearing pushing tool from Tool Kit.
21. Reattach end cap.
22. **If the air motor is lubricated**, apply a few drops of Gast #AD220 lubricant into ports and rotate shaft by hand for a few rotations.

Clearances

Model	Total End Clearance In./mm	Top Clearance In./mm
1AM/1UP	0.0020/0.0508	0.0015/0.0381
2AM	0.0025/0.0635	0.0015/0.0381
2AM*	0.0025/0.0635	0.0025/0.0635
4AM	0.0035/0.0889	0.0015/0.0381
4AM*	0.0035/0.0889	0.0025/0.0635
6AM	0.0035/0.0889	0.0015/0.0381
8AM	0.0048/0.1219	0.0015/0.0381
16AM	0.0060/.1524	0.0015/0.0381
* Models with the last three digits greater than 500 (i.e. 2AM XXX-501)		



Disposal (Please note current regulations)

Parts of the air motor or air powered gear motor, shafts, cast iron or aluminum castings, gear wheels as well as rolling contact bearings may be recycled as scrap metal.

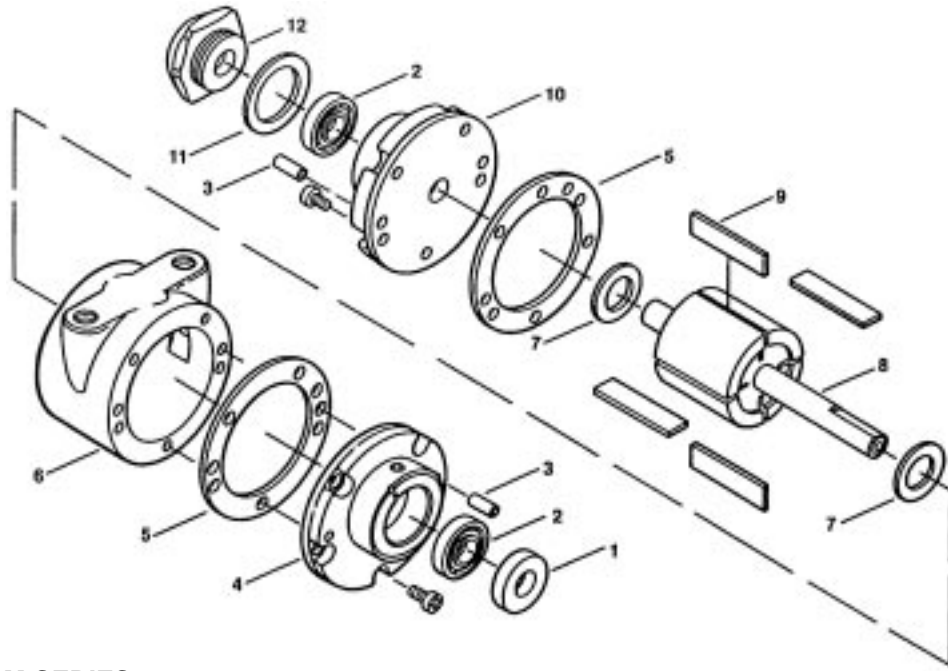

1AM SERIES

REF#	DESCRIPTION	QTY	1AM-NCC-12	1AM-NCW-14	1AM-NRV-39A	1AM-NRV-56	1AM-NRV-60	1AM-NRV-63A
1 Δ	SEAL	1	AC190A	AC190A	AC190A	AC190A	AC190A	AC190A
2 Δ	BEARING	2	AG549	AG549	AG549	AG549	AG549	AG549
3	DOWEL PIN	4	D324A	D324A	D324A	D324A	D324A	D324A
4	DRIVE END PLATE	1	AC537	AC539	AC520	AC520D	AC520D	AC520
5 ΔΔ	SHIMS	2	AC527B	AC527B	AC527B	AC527B	AC527B	AC527B
6	BODY	1	AC521	AC521	AC191	AC191	AC191	AC191
7	CAM RING	2			AC195	AC195	AC195	AC195
8	ROTOR ASSEMBLY	1	AC524	AC536	AC193	AC187	AC607	AC193B
9 Δ	VANE	4 8	AC205A	AC205A	AC259A	AC259A	AC259A	AC259A
10	DEAD END PLATE	1	AC538	AC540	AC192	AC192	AC192	AC192
11 Δ	END CAP GASKET	1	AC229	AC229	AC229	AC229	AC229	AC229
12	DEAD END CAP	1	AC228A	AC228A	AC228A	AC228A	AC228A	AC228A
*** Δ	MUFFLER	1	AF350	AF350	AF350	AF350	AF350	AF350
***	FOAM	1	AG896	AG896	AG896	AG896	AG896	AG896
***	SERVICE KIT	1	K200	K200	K201	K201	K278	K278

1UP SERIES

REF#	DESCRIPTION	QTY	1UP-NCC-1A	1UP-NCW-2A	1UP-NRV-3A	1UP-NRV-4	1UP-NRV-10	1UP-NRV-11
1 Δ	SEAL	1	AC190A	AC190A	AC190A	AC190A	AC190A	AC190A
2 Δ	BEARING	2	AG549	AG549	AG549	AG549	AG549	AG549
3	DOWEL PIN	4	D324A	D324A	D324A	D324A	D324A	D324A
4	DRIVE END PLATE	1	AC616	AC520B	AC520	AC520D	AC520	AC520D
5 ΔΔ	SHIMS	2	AC527B	AC527B	AC527B	AC527B	AC527B	AC527B
6	BODY	1	AE899	AE899	AE898	AE898	AE898	AE898
7	CAM RING	2			AC195	AC195	AC195	AC195
8	ROTOR ASSEMBLY	1	AE896	AE895	AE897	AF746	AE319	AE333
9 Δ	VANE	4 8	AE893	AE893	AE894	AE894	AE894	AE894
10	DEAD END PLATE	1	AC617	AC192A	AC192	AC192	AC192	AC192
11 Δ	END CAP GASKET	1	AC229	AC229	AC229	AC229	AC229	AC229
12	DEAD END CAP	1	AC228A	AC228A	AC228A	AC228A	AC228A	AC228A
*** Δ	MUFFLER	1	AF350	AF350	AF350	AF350	AF350	AF350
***	FOAM	1	AG896	AG896	AG896	AG896	AG896	AG896
***	SERVICE KIT	1	K285	K285	K286	K286	K298	K298

*** Item not shown.

Δ Denotes parts included in the Service Kit.

ΔΔ Parts listed are for stock models manufactured prior to 1998. For specific OEM models, please consult the factory. When corresponding about or ordering parts, please give complete model and serial numbers. Exploded views are shown for reference only. Units may vary depending upon specific model.

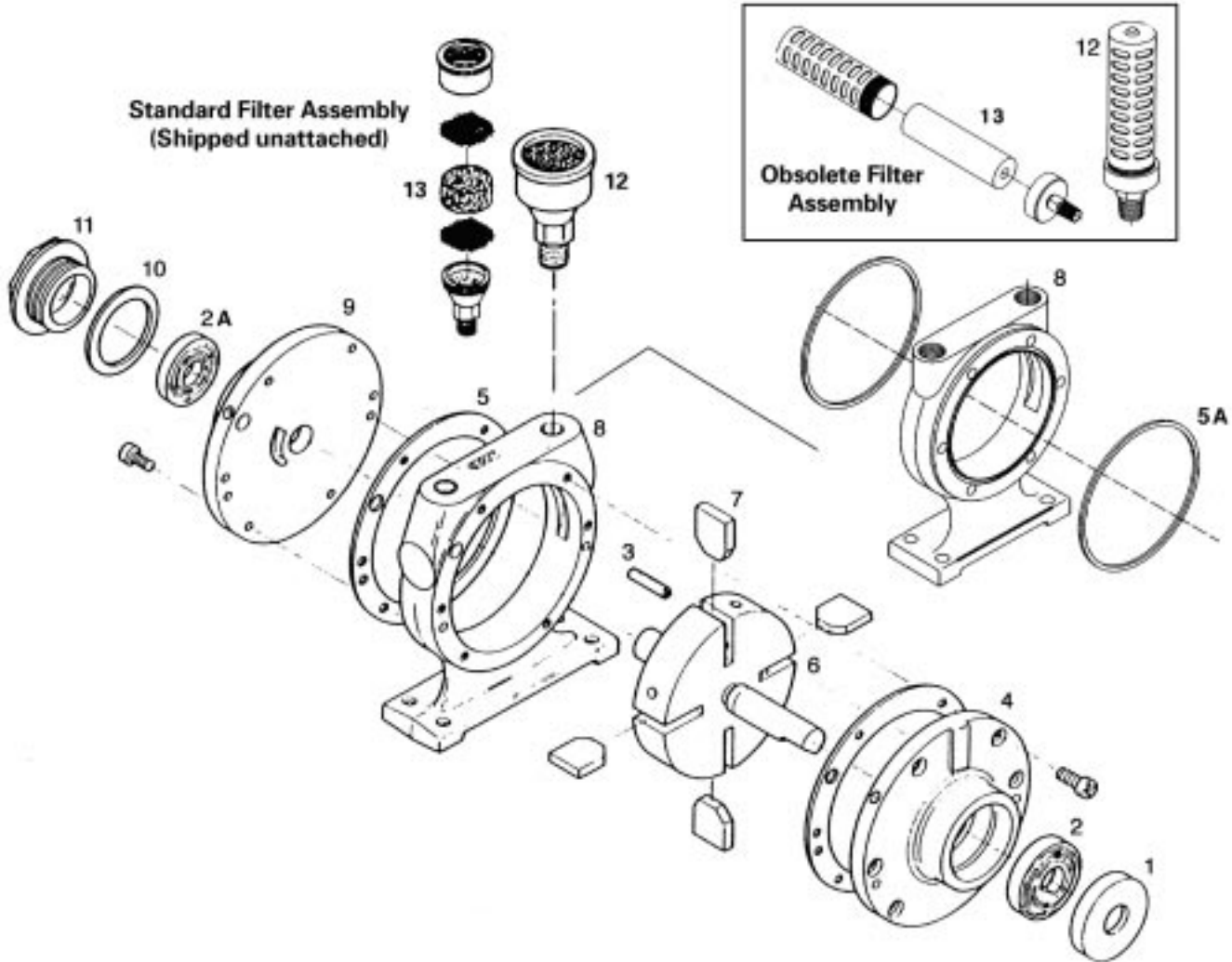

2AM SERIES

REF#	DESCRIPTION	QTY	2AM-FCC-1	2AM-NCW-7A	2AM-FCW-13	2AM-NCC-16	2AM-NCC-43A	2AM-ACC-88 METRIC
1 Δ	SHAFT SEAL	1	AA466B	AA466B	AA466B	AA466B	B2328	B2328
2 Δ	DRIVE END BEARING	1	AA299J	AA299J	AA299J	AA299J	AB519	AB519
2A Δ	DEAD END BEARING	1	AA299J	AA299J	AA299J	AA299J	AA299J	AA299J
3	DOWEL PIN	4	AB162	AB162	AB162	AB162	AB162C	AB162C
4	DRIVE END PLATE	1	AC720	AC726	AC722	AC724	AG708	AK425A
5 Δ **	SHIMS	2	B330	B330	B330	B330	B330	B330
6	ROTOR ASSEMBLY	1	AA470A	AA489A	AA489A	AA470A	AM449A	AM449B
7 Δ	VANE	4	AA13B	AA13B	AA13B	AA13B	AA13B	AA13B
8	BODY	1	AA477	AA467	AA477	AA467	AA467	AA467F
9	DEAD END PLATE	1	AC721	AC723	AC723	AC721	AC721	AB622N
10 Δ	END CAP GASKET	1	AA46	AA46	AA46	AA46	AA46	AA46
11	END CAP	1	AM307D	AM307D	AM307D	AM307D	AM307D	AM307D
12	MUFFLER ASSEMBLY	1	AL445	AL445	AL445	AL445	AL445	AL445
13	MUFFLER FELT	1	AC983	AC983	AC983	AC983	AC983	AC983
***	SERVICE KIT	1	K202	K202	K202	K202	K203A	K203A

*** Item not shown.

** #AL484 (5A) O-ring replaces shim on some models.

Δ Denotes parts included in the Service Kit.

For specific OEM models, please consult the factory.

When corresponding about or ordering parts, please give complete model and serial numbers. Exploded views are shown for reference only. Units may vary depending upon specific model.

EXPLODED PRODUCT VIEWS, PARTS & ORDERING INFORMATION 4AM SERIES

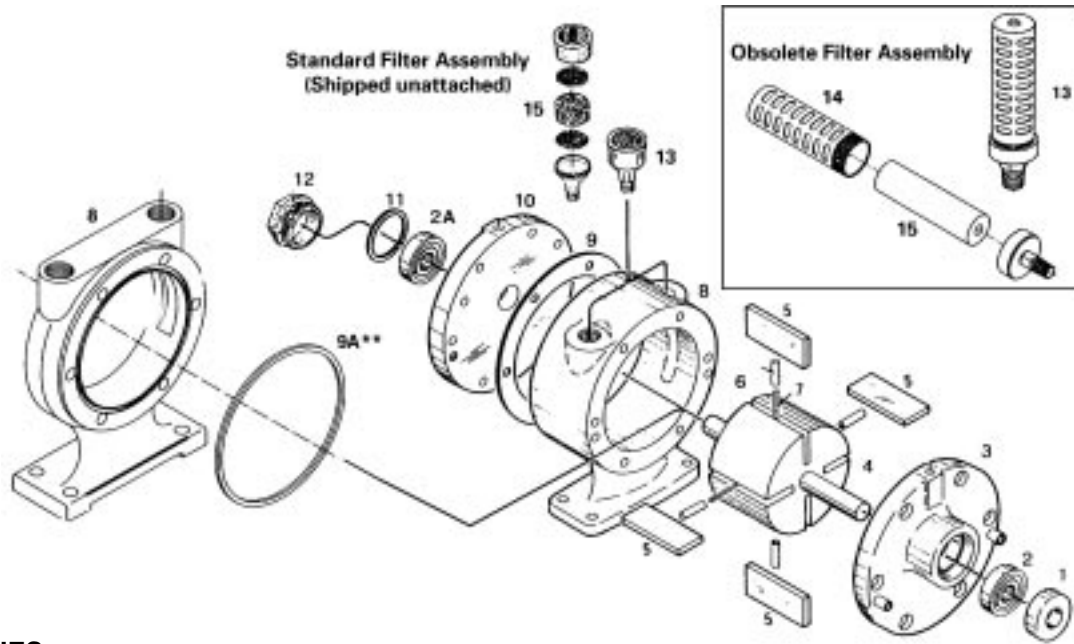

4AM SERIES

REF#	DESCRIPTION	QTY	4AM-FRV-13C	4AM-NRV-22B	4AM-FRV-24	4AM-NRV-50C	4AM-NRV-54A	4AM-NRV-70C	4AM-ARV-119 METRIC	4AM-ARV-120 METRIC
1 Δ	SHAFT SEAL	1	AC466B	AC466B	NAS2	B2328	AA466B	B2328	B2328	B2328
2 Δ	DRIVE END BEARING	1	AA299J	AA299J	AA299J	AB519	AA299J	AB519	AB519	AB519
2A Δ	DEAD END BEARING	1	AA299J	AA299J	AA299J	AA299J	AA299J	AA299J	AA299J	AA299J
3	DRIVE END PLATE	1	AC727	AC665	AC727	AG707	AC665	AG707	AK425A	AK425A
4	ROTOR ASSEMBLY	1	AB617	AB617	AM426	AM455A	AM411	AM319A	AM455C	AM455B
5 Δ	VANE	4 8	AB876	AB876	AB876	AB876	AB876	AB876	AB876	AB876
6 Δ	PUSH PINS	4 8	AM467	AM467	AM467	AM467	AM467	AM467	AM467	AM467
7 Δ	VANE SPRING	2 4	AM466	AM466	AM466	AM466	AM466	AM466	AM466	AM466
8	BODY	1	AM425	AM410	AM425	AM410	AM410	AM410	AM410M	AM410M
9 Δ **	SHIMS	2	B330	B330	B330	B330	B330	B330	B330	B330
10	DEAD END PLATE	1	AC728	AC728	AC727	AC728	AC728	AC728	AB622M	AB622M
11 Δ	END CAP GASKET	1	AA46	AA46		AA46	AA46	AA46	AA46	AA46
12	DEAD END CAP	1	AM307D	AM307D		AM307D	AM307D	AM307D	AM307D	AM307D
13	MUFFLER ASSEMBLY	1	AL445	AL445	AL445	AL445	AL445	AL445	AL445	AL445
14 Δ	MUFFLER CARTRIDGE	1	AL458	AL458	AL458	AL458	AL458	AL458	AL458	AL458
15 Δ	MUFFLER FELT	1	AC983	AC983	AC983	AC983	AC983	AC983	AC983	AC983
***	SERVICE KIT	1	K205	K205	K205G	K206A	K279	K280A	K206C	K206B

4AM SERIES

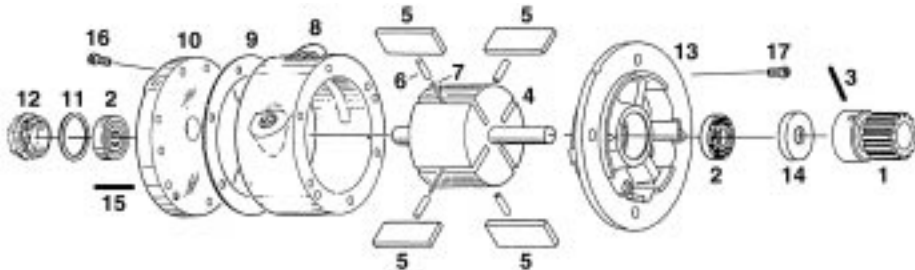

REF#	DESCRIPTION	QTY	4AM-RV-75
1	GEAR STD.	1	AA294
2 Δ	BEARING	2	AA299J
3	PIN	1	AA297
4	ROTOR	1	AA293
5 Δ	VANE	4	AB876
6 Δ	SPRING PIN	4	AM467
7 Δ	SPRINGS	2	AM466
8	BODY	1	AM410
9 Δ	SHIMS	2	B330
10	DEAD END PLATE	1	AC728
11 Δ	END CAP GASKET	1	AA46
12	END CAP	1	AM307D
13	DRIVE END PLATE	1	AA424
14	SEAL	1	AA466B
15	DOWEL PINS	4	AB162
16	1/4-28 x .50 PFHMS	6	BB631
17	1/4-28 x .625 SHCS	6	BB634
***	SERVICE KIT	1	K205

*** Item not shown.

** #AL484 (9A) O-ring replaces shim on some models.

Δ Denotes parts included in the Service Kit.

For specific OEM models, please consult the factory.

When corresponding about or ordering parts, please give complete model and serial numbers.

Exploded views are shown for reference only.

Units may vary depending upon specific model.

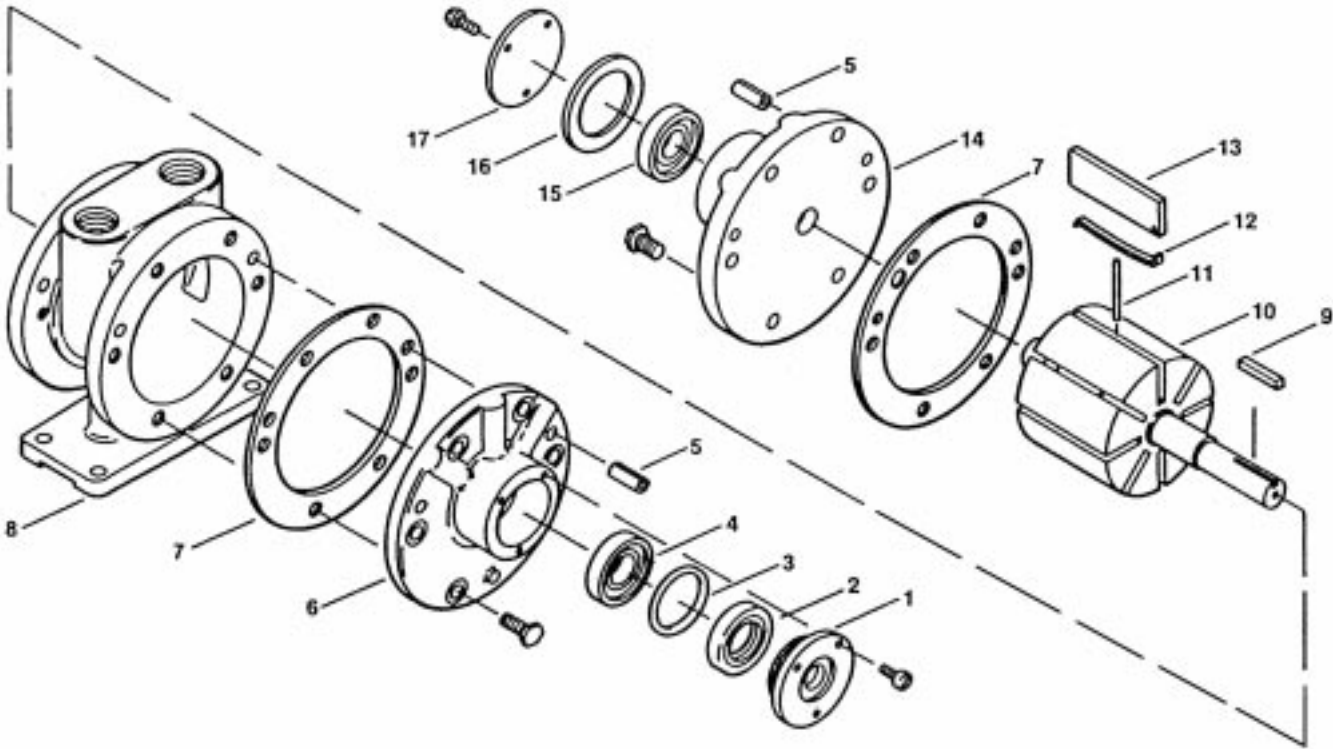

6AM SERIES

REF#	DESCRIPTION	QTY	6AM-FRV-5A	6AM-NRV-7A	6AM-NRV-22A NEMA	6AM-FRV-23A	6AM-ARV-54	6AM-ARV-55	6AM-NRV-11A
1	DRIVE END CAP	1	AD642A	AD642A	AD642A	AD642A	AC988	AC988	AD642A
2 Δ	SHAFT SEAL	1	AC849	AC849	AC849	AC849	AK423	AK423	AC849
3 Δ	O-RING	1	AD649	AD649	AD649	AD649	AC989	AC989	AD649
4 Δ	DRIVE END BEARING	1	AD638A	AD638A	AD638A	AD638A	AC894B	AC894B	AD638A
5	DOWEL PIN	4	AB162	AB162	AB162C	AB162	AB162C	AB162C	AB162C
6	DRIVE END PLATE	1	AD651	AD666	AD667	AD651	AK424	AK424	AD667
7 Δ	BODY GASKET	2	AD641	AD641	AD641	AD641	AD641	AD641	AD641
8	BODY	1	AD650A	AD665	AD665	AD650A	AD665D	AD665D	AD665
9	KEY	1	AB136	AB136	AB136	AB136	AK422	AK422	AB136
10	ROTOR ASSEMBLY	1	AD652	AD652	AC398	AC779	AD648E	AD648D	AD648
11 Δ	PUSH PIN	2	AD655A	AD655A			AD655A		AD655A
		4			AD655A	AD655A		AD655A	
12 Δ	VANE SPRING	4	AD692	AD692			AD692		AD692
		8			AD692	AD692		AD692	
13 Δ	VANE	4	AD691	AD691			AD691		AD691
		8			AD691	AD691		AD691	
14	DEAD END PLATE	1	AD651	AD651	AD651	AD651	AD651	AD651	AD651
15 Δ	DEAD END BEARING	1	AB519	AB519	AB519	AB519	AB519	AB519	AB519
16 Δ	END CAP GASKET	1	AD644	AD644	AD644	AD644	AD644	AD644	AD644
17	DEAD END CAP	1	AD643	AD643	AD643	AD643	AD643	AD643	AD643
***	MUFFLER ASSEMBLY	1	AC990	AC990	AC990	AC990	AC990	AC990	AC990
***	MUFFLER FELT	1	AC993	AC993	AC993	AC993	AC993	AC993	AC993
***	SERVICE KIT	1	K208	K208	K281	K281	K281A	K281B	K208

*** Item not shown.

Δ Denotes parts included in the Service Kit.

For specific OEM models, please consult the factory.

When corresponding about or ordering parts, please give complete model and serial numbers. Exploded views are shown for reference only. Units may vary depending upon specific model.

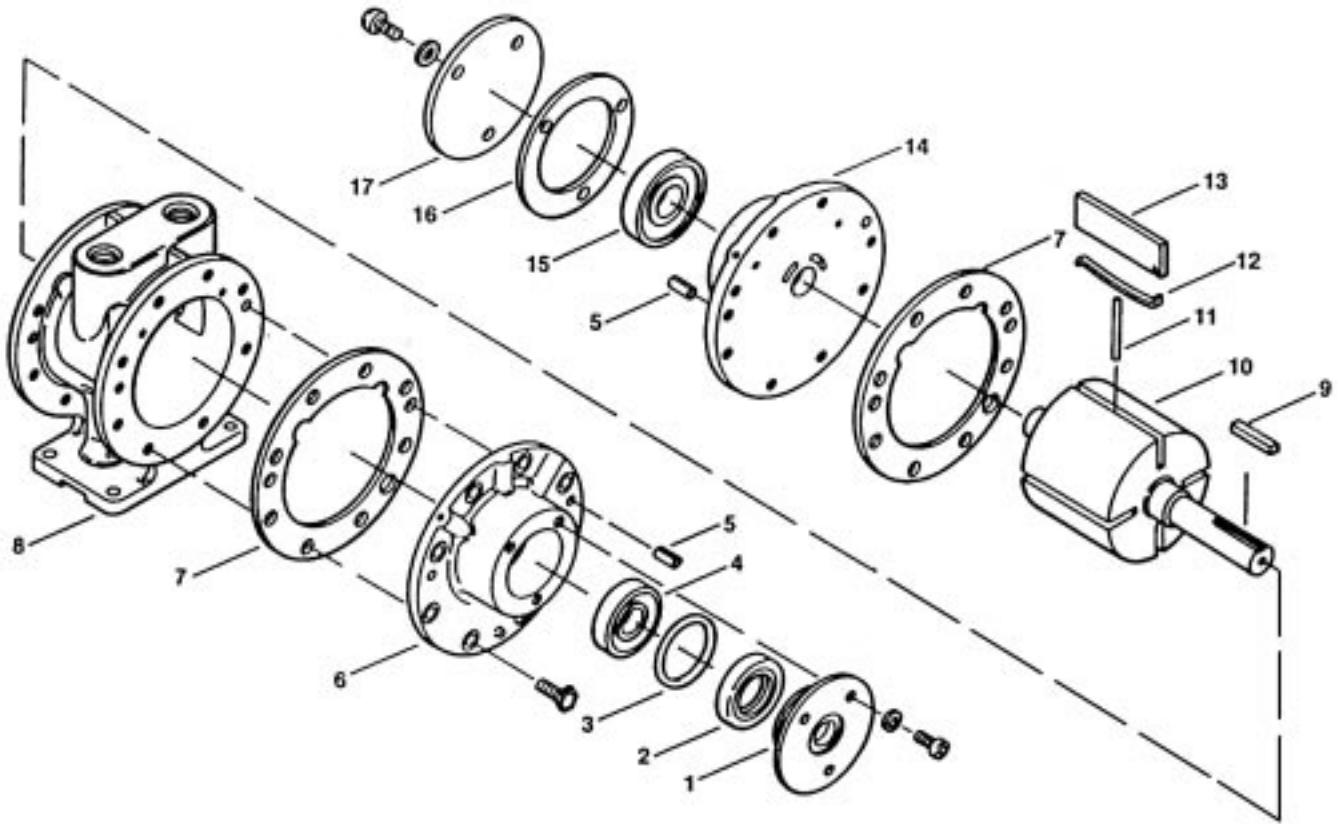

8AM SERIES

REF#	DESCRIPTION	QTY	8AM-FRV-2B	8AN-NRV-5B	8AM-NRV-28A	8AM-FRV-30A	8AM-NRV-32A	8AM-NRV-42A	8AM-ARV-70 METRIC	8AM-ARV-71 METRIC
1	DRIVE END CAP	1	AC835A	AC835A	AC988	AC835A	AC988	AC835A	AC988	AC988
2 Δ	SHAFT SEAL	1	AC839	AC839	AB936	AC839	AB936	AC839	AK420	AK420
3 Δ	O-RING	1	AC808	AC808	AC989	AC808	AC989	AC808	AC989	AC989
4 Δ	DRIVE END BEARING	1	AA735B	AA735B	AB927	AA735B	AB927	AA735B	AB927	AB927
5	DOWEL PIN	4	AB162	AB162	AB162	AB162	AB162	AB162	AB162	AB162
6	DRIVE END PLATE	2	AC964	AC963	AC965	AC964	AC965	AC963	AK421	AK421
7 Δ	BODY GASKET	2	AC888	AC888	AC888	AC888	AC888	AC888	AC888	AC888
8	BODY	1	AC877A	AC878C	AC878C	AC877A	AC878C	AC878C	AC878G	AC878G
9	KEY	1	AB136D	AB136D	AB136D	AB136D	AB136D	AB136D	AK668	AK668
10	ROTOR ASSEMBLY	1	AC977	AC977	AC986	AC977A	AC986A	AC977A	AC986D	AC986C
11 Δ	PUSH PIN	2	AC879	AC879	AC879				AC879	
		4				AC879	AC879	AC879		AC879
12 Δ	VANE SPRING	4	AC817	AC817	AC817				AC817	
		8				AC817	AC817	AC817		AC817
13 Δ	VANE	4	AC816	AC816	AC816				AC816	
		8				AC816	AC816	AC816		AC816
14	DEAD END PLATE	1	AC964	AC964	AC964	AC964	AC964	AC964	AC964	AC964
15 Δ	DEAD END BEARING	1	AC894B	AC894B	AC894B	AC894B	AC894B	AC894B	AC894B	AC894B
16 Δ	END CAP GASKET	1	AC837	AC837	AC837	AC837	AC837	AC837	AC837	AC837
17	DEAD END CAP	1	AC836	AC836	AC836	AC836	AC836	AC836	AC836	AC836
***	MUFFLER ASSEMBLY	1	AC990	AC990	AC990	AC990	AC990	AC990	AC990	AC990
***	MUFFLER FELT	1	AC993	AC993	AC993	AC993	AC993	AC993	AC993	AC993
***	SERVICE KIT	1	K210	K210	K211	K283	K282	K283	K282A	K282B

*** Item not shown.

Δ Denotes parts included in the Service Kit.

For specific OEM models, please consult the factory.

When corresponding about or ordering parts, please give complete model and serial numbers. Exploded views are shown for reference only. Units may vary depending upon specific model.

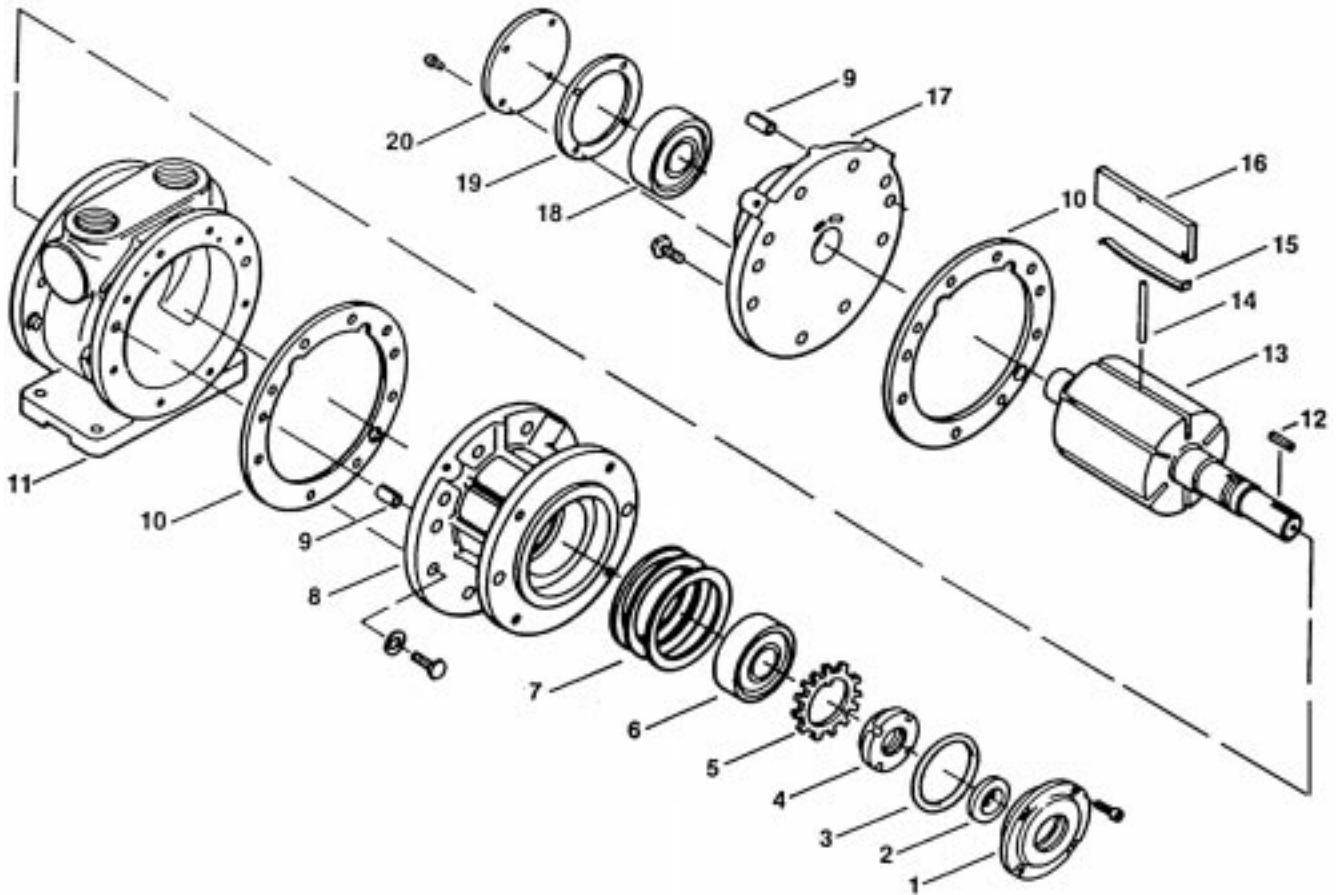

16AM SERIES

REF#	DESCRIPTION	QTY	16AM-FCC-2	16AM-FRV-2	16AM-FRV-13	16AM-FCW-
28						
1	DRIVE END CAP	1	AD816	AD816	AD816	AD816
2 Δ	SEAL	1	AC627	AC627	AC627	AC627
3 Δ	O-RING	1	AD823	AD823	AD823	AD823
4	LOCKNUT	1	AD784	AD784	AD784	AD784
5 Δ	LOCKWASHER	1	AD712	AD712	AD712	AD712
6 Δ	DRIVE END BEARING	1	AB777A	AB777A	AB777A	AB777A
7	SPACER		AD786	AD786	AD786	AD786
8	DRIVE END PLATE	1	AD771A	AD820A	AC323	
9	DOWEL PIN	4	AB162A	AB162A	AB162A	AB162A
10 Δ	SPACER GASKET	2	AD788	AD788	AD788	
11	BODY	1	AD770	AD819	AD819	AD770B
12	DRIVE KEY	1	AC628	AC628	AB136D	AC628
13	ROTOR ASSEMBLY	1	AD775	AD794	AE807	
14 Δ	PUSH PIN	3		AD822	AD822	
15 Δ	VANE SPRING	6		AD796A	AD796A	
16 Δ	VANE	6	AD781	AD795	AD795	AD781
17	DEAD END PLATE	1	AD773A	AD821A	AD821A	
18	DEAD END BEARING	1	AD802	AD802	AD802	AD802
19	END CAP GASKET	1	AG406	AG406	AG406	AG406
20	DEAD END CAP	1	AG405	AG405	AD405	AG405
***	SERVICE KIT	1	K212	K213	K213	K212

*** Item not shown.

Δ Denotes parts included in the Service Kit.

For specific OEM models, please consult the factory.

When corresponding about or ordering parts, please give complete model and serial numbers. Exploded views are shown for reference only. Units may vary depending upon specific model.

General Information:

The product nameplate specifies all information required when ordering parts or requests for information. The type of lubricant required for unit is also specified on the nameplate.

Product Use Criteria:

- All worm gear reducers require that the air motor be mounted so that the inlet and exhaust ports are at a 90° angle to the centerline of the reducer output shaft.
- Gear reducers are NOT self-locking. If a brake is required for safety, as in the case of air pressure failure, etc., contact your Gast Distributor/Representative.
- Worm gear reducers are shipped with a plug in the top pipe plug. The plug must be removed and the breather plug installed for proper operation.
- Operating an air motor without venting will create internal pressure build-up which can damage the internal parts of the gear reducer.
- Check the oil level in units which have been stored or not operated for a period of time.
- Gear motors require proper lubrication. Insufficient oil level can cause loss of performance, damage or failure of the gear reducer.

Gear Reducer Specifications

Model	GR11	GR20	GR25
Speed Range (Reducer Output Shaft)	33.3 to 400 RPM	30 to 300 RPM	20 to 200 RPM
Gear Reduction	15:1	10:1	15:1
Maximum Allowable End Thrust With Zero Overhung Load. (Reducer Output Shaft)	100 lbs/45,4 kg	200 lbs/90,8 kg @300 RPM to 800 lbs/363,2 kg at 30 RPM	250 lbs/113,5 kg at 200 RPM to 800 lbs/363,2 kg at 20 RPM
Maximum Allowable Overhung Load With Zero End Thrust. (Reducer Output Shaft)	100 lbs/45,4 kg at 333 RPM to 200 lbs/90,8 kg at 33.3 RPM	200 lbs/90,8 kg at 300 RPM to 600 lbs/272,4 kg at 30 RPM	200 lbs/90,8 kg at 200 RPM to 600 lbs/272,4 kg at 20 RPM
Lubrication	Use a 300 ssu at 100°F/38°C turbine quality lubricant – Gast #AG292A, Gulf Harmony 53, Shell Tellus 33, Socony DTE heavy medium or Humble Nuto 53. For horizontal operation , remove both plugs and add oil to top hole until other hole overflows. For vertical operation , fill to overflow point of upper most hole.		

Worm Gear Reducer Series A-F

Gear Reducer Specifications

All output shafts are in the standard location.

Model	Air Motor	Ratio
AG803	4AM	20:1
AG805	4AM	40:1
AG807	4AM	60:1
AG809	6AM	10:1
AG811	6AM	20:1
AG816	8AM	20:1

Service, Parts or Repair

For service, parts or repair of the worm gear reducer, contact the manufacturer listed on the nameplate.

Change output shaft direction

1. Remove drain plug and drain oil from unit.
2. Remove end cover and seal cage cap screws. While supporting output shaft, remove end cover and shims from unit. Keep shims with cover.
3. Remove output shaft and seal cage together from extension side. Keep shims with seal cage.
4. Insert seal cage, shims and sub-assembly into housing from the side opposite from which they were removed.
5. Insert seal cage cap screws and tighten with light pressure.
6. Assemble end cover with shims. Insert end cover cap screws and tighten with light pressure.
7. Turn high speed shaft in both directions to check that gear train is running freely.
8. Cross-tighten seal cage and end cover cap screws.

EXPLODED PRODUCT VIEWS, PARTS & ORDERING INFORMATION

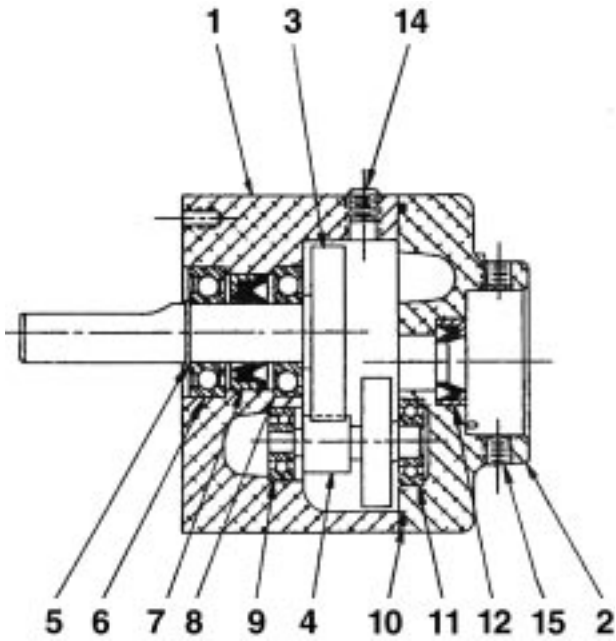

GR11 SERIES

REF#	DESCRIPTION	QTY	PART NO.
1	GEAR HOUSING	1	AC737
2	GEAR HOUSING COVER	1	AC736
3	GEAR SHAFT	1	AC739
4	CLUSTER GEAR	1	AC738
5	SNAP-RING	1	AE189
6	BEARING	1	AE196A
7	SEAL	1	AA517A
8	BEARING	1	AA498
9	BEARING	1	AE195
10	O-RING	1	AD823
11	BEARING	1	AE197
12	SEAL	1	AA623D
13	SCREWS	4	BB542
14	PIPE PLUG	2	BA500
15	SET SCREW	2	BB626
***	DOWEL PIN	2	AE882

*** Item not shown.

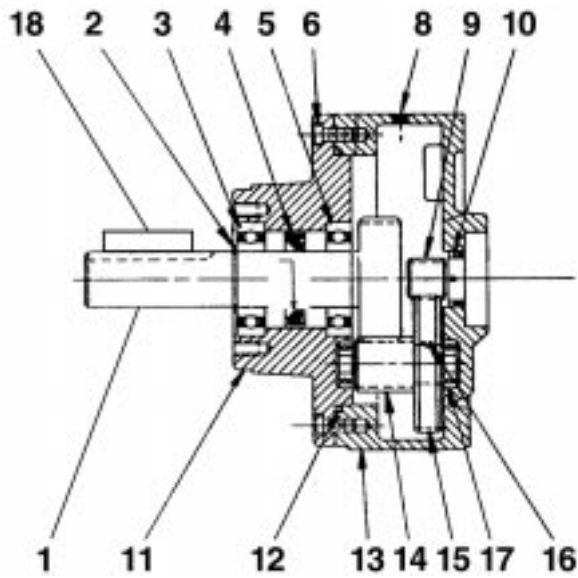

GR20 SERIES

REF#	DESCRIPTION	QTY	PART NO.
1	GEAR SHAFT - OUTPUT	1	AE848
2	RETAINING RING	1	AE853
3	BEARING	1	AE858
4	OIL SEAL	1	AE852
5	BEARING	1	AE857
6	SCREW	6	BB652
***	DOWEL PIN	2	AF482
8	MAGNETIC DRAIN PLUG	2	AH471
9	GEAR - INPUT	1	AA294
10	OIL SEAL	1	AE851
11	HOUSING COVER	1	AE849
12	O-RING	1	AE854
13	GEAR HOUSING	1	AE850
14	GEAR SHAFT	1	AE845
15	GEAR - INTERMEDIATE	1	AE846
16	KEY	1	AE855
17	BEARING	2	AG549
18	KEY	1	AC628

*** Item not shown.

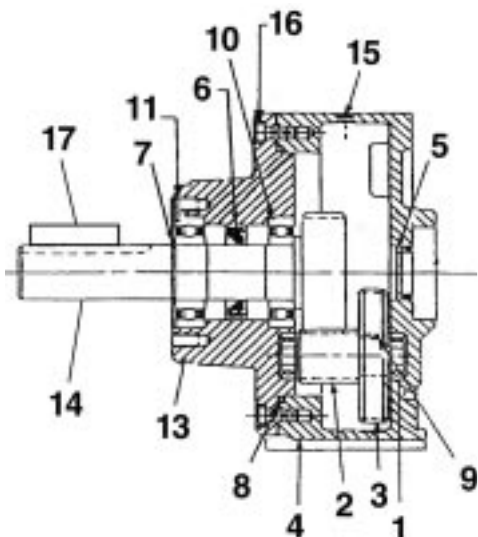

GR25 SERIES

REF#	DESCRIPTION	QTY	PART NO.
1	BEARING	2	AG549
2	GEAR SHAFT	1	AE845
3	GEAR INTERMEDIATE	1	AE846
4	GEAR HOUSING	1	AE850
5	SEAL	1	AE851
6	SEAL	1	AE852
7	RETAINING RING	1	AE853
8	O-RING	1	AE854
9	KEY	1	AE855
10	BEARING	1	AE857
11	BEARING	1	AE858
***	DOWEL PIN	2	AF482
13	HOUSING COVER	1	AH278
14	GEAR SHAFT - OUTPUT	1	AH279
15	MAGNETIC DRAIN PLUG	2	AH471
16	SCREWS	6	BB652
17	KEY	1	AC628

WARRANTY

Gast finished products, when properly installed and operated under normal conditions of use, are warranted by Gast to be free from defects in material and workmanship for a period of twelve (12) months from the date of purchase from Gast or an authorized Gast Representative or Distributor. In order to obtain performance under this warranty, the buyer must promptly (in no event later than thirty (30) days after discovery of the defect) give written notice of the defect to Gast Manufacturing Incorporated, PO Box 97, Benton Harbor Michigan USA 49023-0097 or an authorized Service Center (unless specifically agreed upon in writing signed by both parties or specified in writing as part of a Gast OEM Quotation). Buyer is responsible for freight charges both to and from Gast in all cases.

This warranty does not apply to electric motors, electrical controls, and gasoline engines not supplied by Gast. Gast's warranties also do not extend to any goods or parts which have been subjected to misuse, lack of maintenance, neglect, damage by accident or transit damage.

THIS EXPRESS WARRANTY EXCLUDES ALL OTHER WARRANTIES OR REPRESENTATIONS EXPRESSED OR IMPLIED BY ANY LITERATURE, DATA, OR PERSON. GAST'S MAXIMUM LIABILITY UNDER THIS EXCLUSIVE REMEDY SHALL NEVER EXCEED THE COST OF THE SUBJECT PRODUCT AND GAST RESERVES THE RIGHT, AT ITS SOLE DISCRETION, TO REFUND THE PURCHASE PRICE IN LIEU OF REPAIR OR REPLACEMENT.

GAST WILL NOT BE RESPONSIBLE OR LIABLE FOR INDIRECT OR CONSEQUENTIAL DAMAGES OF ANY KIND, however arising, including but not limited to those for use of any products, loss of time, inconvenience, lost profit, labor charges, or other incidental or consequential damages with respect to persons, business, or property, whether as a result of breach of warranty, negligence or otherwise. Notwithstanding any other provision of this warranty, BUYER'S REMEDY AGAINST GAST FOR GOODS SUPPLIED OR FOR NON-DELIVERED GOODS OR FAILURE TO FURNISH GOODS, WHETHER OR NOT BASED ON NEGLIGENCE, STRICT LIABILITY OR BREACH OF EXPRESS OR IMPLIED WARRANTY IS LIMITED SOLELY, AT GAST'S OPTION, TO REPLACEMENT OF OR CURE OF SUCH NONCONFORMING OR NON-DELIVERED GOODS OR RETURN OF THE PURCHASE PRICE FOR SUCH GOODS AND IN NO EVENT SHALL EXCEED THE PRICE OR CHARGE FOR SUCH GOODS. GAST EXPRESSLY DISCLAIMS ANY WARRANTY OF MERCHANTABILITY OR FITNESS FOR A PARTICULAR USE OR PURPOSE WITH RESPECT TO THE GOODS SOLD. THERE ARE NO WARRANTIES WHICH EXTEND BEYOND THE DESCRIPTIONS SET FORTH IN THIS WARRANTY, notwithstanding any knowledge of Gast regarding the use or uses intended to be made of goods, proposed changes or additions to goods, or any assistance or suggestions that may have been made by Gast personnel.

Unauthorized extensions of warranties by the customer shall remain the customer's responsibility.

CUSTOMER IS RESPONSIBLE FOR DETERMINING THE SUITABILITY OF GAST PRODUCTS FOR CUSTOMER'S USE OR RESALE, OR FOR INCORPORATING THEM INTO OBJECTS OR APPLICATIONS WHICH CUSTOMER DESIGNS, ASSEMBLES, CONSTRUCTS OR MANUFACTURES.

This warranty can be modified only by authorized Gast personnel by signing a specific, written description of any modifications.

MAINTENANCE RECORD

DATE	PROCEDURE PERFORMED

TROUBLESHOOTING CHART

Problem					
Low Torque	Low Speed	Won't Run	Runs Hot	Runs Well Then Slows Down	Reason & Remedy For Problem.
•	•	•			Dirt or foreign material present. Inspect and clean.
•	•	•			Internal rust. Inspect and clean.
•	•	•	•	•	Vanes misaligned. Realign vanes.
•	•				Low air pressure. Increase pressure.
	•				Air line too small. Install larger line(s).
	•			•	Restricted exhaust. Inspect and repair.
•	•	•		•	Motor is jammed. Disassemble and repair.
	•			•	Air source inadequate. Inspect and repair.
	•			•	Air source too far from motor. Reconfigure setup.

We have Gast Authorized Repair Facilities throughout the world. For the most up-to-date listing, contact one of our sales offices below:

World Headquarters
 P.O. Box 97
 2550 Meadowbrook Rd.
 Benton Harbor, MI 49023-0097
 Ph: 269/926-6171
 FAX: 269/925-8288
 www.gastmfg.com

Eastern Sales Office
 505 Washington Ave.
 Carlstadt, NJ 07072
 Ph: 201/933-8484
 FAX: 201/933-5545
 www.gastmfg.com

European Sales & Service Headquarters
 Beech House Knaves Beech
 Business Centre
 Loudwater, High Wycombe
 Bucks, England HP10 9SD
 Tel: +44 1628 551500
 Fax: +44 1628 551590
 www.gastltd.com

Gast Hong Kong
 Unit 12, 21/F, Block B
 New Trade Plaza
 6, On Ping Street, Shatin
 N. T. Hong Kong
 Ph: (852) 2690 1008
 Fax: (852) 2690 1012
 www.gasthk.com



ISO 9001 & 14001 CERTIFIED

www.gastmfg.com